

BAUMALIGHT™

**RSS380 RSS580 RSS780
SPLINTER WOOD SPLITTER & PLANER
OPERATOR'S MANUAL**

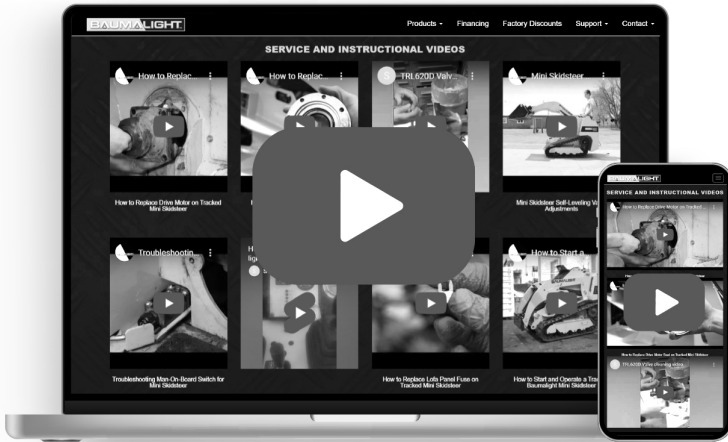

Service And Instructional Videos

Find online at
baumalight.com/support

Following is a list of videos and documents available on Baumalights website and also on YouTube to help and enhance maintaining the wood splitter and planer. The list below was current at the time this manual was issued. Additional content may be available.

Activity ID Number	Activity Name	Description	Item Available
107	Remove Seal.	Remove Seal On Motor Or Load Adapter.	Video
131	Zero-Leak Relief Valve.	Demonstrating And Troubleshooting Zero-Leak.	Video
140	Replace Motor Shaft Seal.	Replace Shaft Seal On Piston Motor.	Video
317	Hydraulic Motor.	Breaking In Replacement Hydraulic Motor.	Video
278	Skidsteer Case Drain Back-Pressure.	What May Cause Skidsteer Case Drain Back-Pressure.	Video
279	Skidsteer Case Drain Back-Pressure.	Testing Case Drain Back-Pressure With Pressure Gauge.	Video
280	Skidsteer Case Drain Back-Pressure.	Testing Case Drain Back-Pressure With Open Coupler.	Video

TABLE OF CONTENTS

1 INTRODUCTION	4
1.1 Overview.....	4
1.2 Intended Use And Foreseeable Misuse	4
2 SAFETY	5
2.1 Safety Alert Symbol and Safety Words	5
2.2 Operational Hazards.....	5
Prepare For Emergencies	6
Replace Safety Signs	6
Do Not Allow Riders	6
Lower Operating Speed	6
Avoid Rollover	7
Avoid Powerlines & Underground Utilities	7
Detach Splinter Safely.....	7
Hazards From Modifying Equipment	7
2.3 Maintenance Hazards.....	9
3 SAFETY SIGNS	10
4 OPERATION	16
4.1 Machine Components	16
4.2 Preparation for Use	16
4.3 Hydraulic Connections	17
4.4 Attach To Skid Steer.....	18
4.5 Attachments	18
4.6 Transporting.....	19
4.7 First Time User Tips	20
4.8 Field Operation	20
4.9 Detach From Skid Steer	22
5 SERVICE AND MAINTENANCE	23
5.1 Daily	23
5.2 Motor Shaft Seal - RSS780 Only.....	23
5.3 Zero Leak Case Drain Relief - RSS780 Only	24
6 TROUBLESHOOTING	25
7 STORAGE	26
7.1 Storing Splinter.....	26
7.2 Remove From Storage	26
BAUMALIGHT ATTACHMENT WARRANTY	27

1 INTRODUCTION

1.1 Overview

Congratulations on your choice of a Baumalight Splinter to complement your wood clearing operation. This equipment has been designed and manufactured to meet the needs of a discriminating buyer for efficient operation.

The Splinter's power comes from the hydraulically-driven motor mounting on a planetary drive, delivering a high amount of torque to the head.

Skid steer must have suitable safety equipment properly installed.

Safe, efficient and trouble free operation of your Splinter requires that you and anyone else who will be operating or maintaining the Splinter, read and understand the Safety, Operation, Maintenance and Troubleshooting information contained within the Operator's Manual.

This manual covers the Baumalight RSS380, RSS580 and RSS780 Splinter. Use the Table of Contents as a guide to locate required information.

Keep this manual handy for frequent reference and to pass on to new operators or owners. Call your Baumalight dealer, distributor or the factory if you need assistance, information or additional copies of the manuals.

OPERATOR ORIENTATION - The directions left, right, front and rear, as mentioned throughout this manual, are as seen from the driver's seat and facing in the direction of travel.

1.2 Intended Use And Foreseeable Misuse

The Splinter is designed to be used by an experienced operator. Operator must be trained in the safe operation of a skid steer and hazards related to using the Splinter and the safe use of the Splinter for the intended purpose. Operators will require personal protective equipment to reduce the risk from some hazards that cannot be completely eliminated or controlled by the design of the Splinter.

Care is required to ensure that the Splinter will not come in contact with metallic objects, stones or other materials.

Splinters are not designed for use in hazardous atmospheres where there is a risk of fire or explosion due to flammable gases or vapors. Use in hazardous, explosive atmospheres is prohibited. Serious injury or death of the operator or bystanders may be caused if Splinter is misused. Misuse may also cause damage to the machine carrying the Splinter.

2 SAFETY

2.1 Safety Alert Symbol and Safety Words

You must read, understand and follow the instructions given by the operating unit manufacturers, as well as the instructions in this manual.

The safety information in this manual is denoted by the safety alert symbol:



This symbol means ATTENTION! BECOME ALERT! YOUR SAFETY IS INVOLVED!

The level of risk is indicated by the following signal words:

 DANGER
DANGER - Indicates a hazardous situation, which, if not avoided, WILL result in death or serious injury.

 WARNING
WARNING - Indicates a hazardous situation, which, if not avoided, could result in death or serious injury.

 CAUTION
CAUTION - Indicates a hazardous situation, which, if not avoided, could result in minor or moderate injury.

NOTICE
NOTICE - Indicates a situation that could result in damage to the equipment or other property.

2.2 Operational Hazards

 WARNING
Prevent serious injury or death.
Read and understand this manual before operating the Splinter.
Always stop engine and remove key before leaving operators seat.
Never allow anyone near the Splinter during operation.
Travel at a safe speed.

 WARNING
Prevent serious injury or death from moving parts.
Moving parts can crush and dismember.
Do not operate without guards and shields in place.
Disconnect and lock out power source before adjusting or servicing.

 WARNING
Use the Splinter only for the designed applications.
Any other use may result in personal injury, damage to equipment and may void the warranty.



WARNING

Prevent serious injury or death.

Verify the Splinter is locked to the skid steer before operation or transport.



WARNING

Protect from flying debris.

Wear proper safety glasses, goggles, or a face shield to protect from flying debris.

Carefully read all safety messages in this manual and on equipment safety signs. Keep safety signs in good condition and replace missing or damaged safety signs.

New equipment components and repair parts must include the current safety decal.

Learn how to properly operate equipment. NEVER operate or work around this equipment without proper instruction, while fatigued or under the influence of alcohol, prescription or non-prescription medication or if feeling ill.

Keep your equipment in proper working condition. Know the regulations and laws that apply to you and your industry. This manual is not to replace any regulations or laws. Additional information may be found at: www.asae.org or www.osha.gov. If you do not understand any part of this manual, contact Baumalight at 866-820-7603.

Prepare For Emergencies

- Be prepared in case of emergencies.
- Keep a fire extinguisher and first aid kit close to the machine.
- Keep emergency phone numbers close to your phone.
- Know your address so emergency services can locate you if an emergency arises.

Replace Safety Signs

- Replace missing or damaged safety signs.
- Safety signs are identified in Section 3 of this manual.
- Replacement safety signs are available from your Baumalight dealer.

Do Not Allow Riders

- NEVER lift or carry anyone on the Splinter.
- NEVER use Splinter as a work platform.
- NEVER allow passengers on the Splinter.

Lower Operating Speed

Keep Splinter low and move at slow speeds on rough or uneven terrain.

Lower operating speed while traveling in heavy conditions.

Avoid Rollover

The equipment may rollover, resulting in death or serious injury. To help prevent rollover:

- Travel at a slow speed.
- Avoid sharp turns & sudden movement on slopes.
- Carry Splinter close to the ground.
- Avoid holes, ditches and other obstructions which may cause equipment to rollover.
- Balance load so weight is evenly distributed and load is stable.
- Use caution when operating on slopes and do not operate on excessively steep slopes.
- Do not exceed load capacity of equipment.

Avoid Powerlines & Underground Utilities

 DANGER
Prevent electrocution.
Death or serious injury can result if equipment comes near or contacts power lines.
Electrocution can occur without direct contact.

- Check clearance before raising equipment.
- Have local utilities locate and mark under ground wires, cables, pipelines and other hazards before operation.

DO NOT leave the operator's seat if any part of the equipment contacts electric lines or cables.

Detach Splinter Safely

Detach splinter on a firm and level surface. Splinter may fall over if detached on unlevel or soft surface. Be sure people, livestock and pets are clear of machinery.

Raised Attachment

 WARNING
Crushing hazard.
Raised, unsupported Splinter can fall, resulting in death or serious injury.
Never enter the area under a raised Splinter.

A raised Splinter can lower unexpectedly, resulting in death or serious injury.

NEVER enter area under a raised Splinter.

Lower Splinter to ground, engage parking brake, shut off engine and remove key before servicing.

Hazards From Modifying Equipment

Do not make any alterations to your Splitter. Altering may cause your equipment to be unsafe and may void the manufacturers' warranty.

Avoid Loud Noise

 **WARNING**

Prolonged exposure to loud noise can cause impairment or loss of hearing.

Wear a suitable hearing protective device such as earmuffs or earplugs to protect against objectionable or uncomfortable loud noises.

Stay Clear Of Moving Parts

 **WARNING**

Moving parts can cause serious injury or death.

Keep shields and guards in place at all times. **DO NOT** operate without shields and guards.

DO NOT wear loose fitting clothing.

Avoid Wood Dust Inhalation

 **WARNING**

Drilling, sawing, sanding or machining wood products can expose you to wood dust, a substance known to the State of California to cause cancer.

Avoid inhaling wood dust or use a dust mask or other safeguards for personal protection. For more information go to www.P65Warnings.ca.gov/wood.

 **WARNING**

Wear an approved dust mask or respirator.

Follow local, state and federal regulations.

2.3 Maintenance Hazards

Before servicing, park machine on a firm and level surface, set parking brake and place a “Do Not Operate” tag on control panel. Read and understand this manual. If you do not understand any part of the manual, contact Baumalight at 866-820-7603.

Always wear face and/or eye protection, safety shoes, and other protective equipment appropriate for the job.

Do not make unauthorized modifications. Contact Baumalight at 866-820-7603 before you weld, cut/drink holes, or make any other modifications.

Always use Baumalight replacement parts.

WARNING

Moving parts can entangle and cut.

Keep clear of moving components.

Follow lockout procedure before servicing.

WARNING

Crushing hazard.

Before performing inspections, service or maintenance:

Park machine on firm, level surface.

Engage parking brake.

Turn engine off and remove key.

Place “Do Not Operate” tag on control panel.

WARNING

Entanglement hazard.

Keep clear of moving components.

Wear proper protective equipment appropriate for the job.

WARNING

Drilling, sawing, sanding or machining wood products can expose you to wood dust, a substance known to the State of California to cause cancer.

Avoid inhaling wood dust or use a dust mask or other safeguards for personal protection. For more information go to www.P65Warnings.ca.gov/wood.

WARNING

Wear an approved dust mask or respirator.

Follow local, state and federal regulations.

3 SAFETY SIGNS

3.1 Safety Signs - RSS380

The two and four panel safety decals are pictorial and have a yellow background. The panel with a triangle indicates the potential hazard. The panel without a triangle indicates how to avoid the hazard.

If any of the decals are missing, are damaged, or if you do not understand the decal, please contact your dealer.

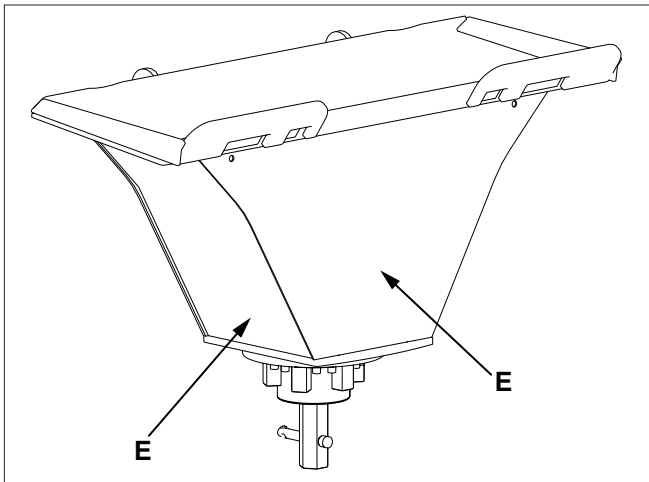
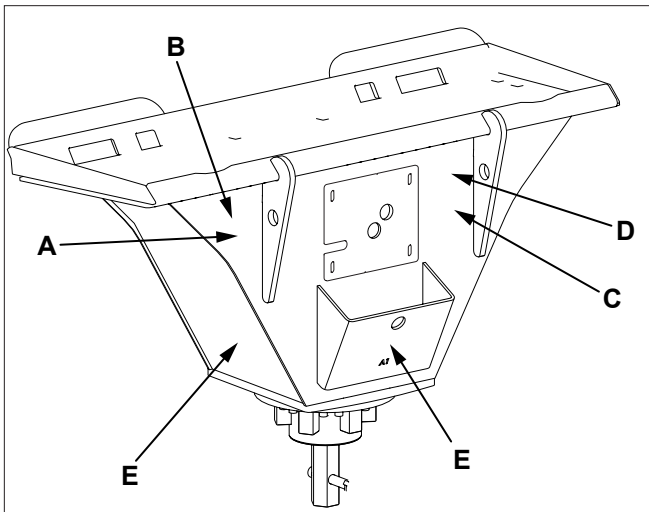

A. D005262  WARNING - P65 warning information.

**WARNING:** This product can expose you to chemicals including 1,3-Butadiene and lead, which are known to the state of California to cause cancer and birth defects or other reproductive harm. For more information go to www.P65Warnings.ca.gov.
D005262

B. D005126  WARNING - Pressurized fluid hazard. Keep away from machine.



C. D005517 ⚠ WARNING - Remove key before servicing.

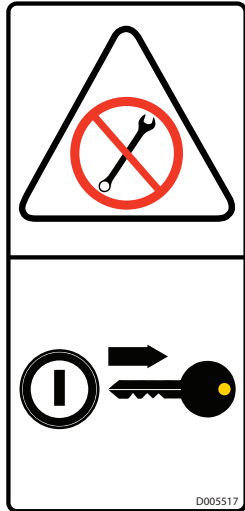

D. D005125 ⚠ WARNING - Read and understand safety signs on the machine and operating instructions in this manual before operating machine.

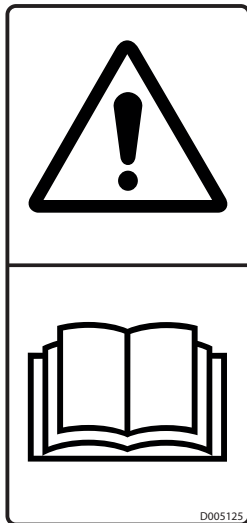

E. D005128 ⚠ WARNING - Rotating auger hazard. Keep back while machine is operating.





3.2 Safety Signs - RSS580

The two and four panel safety decals are pictorial and have a yellow background. The panel with a triangle indicates the potential hazard. The panel without a triangle indicates how to avoid the hazard.

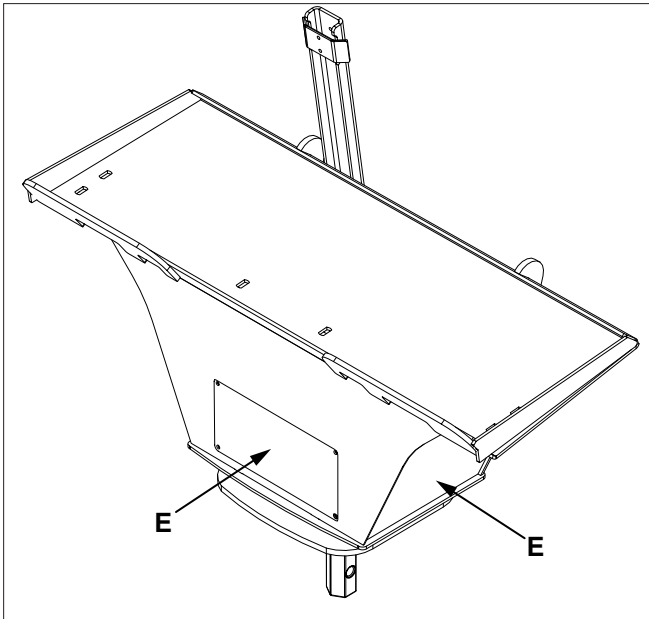
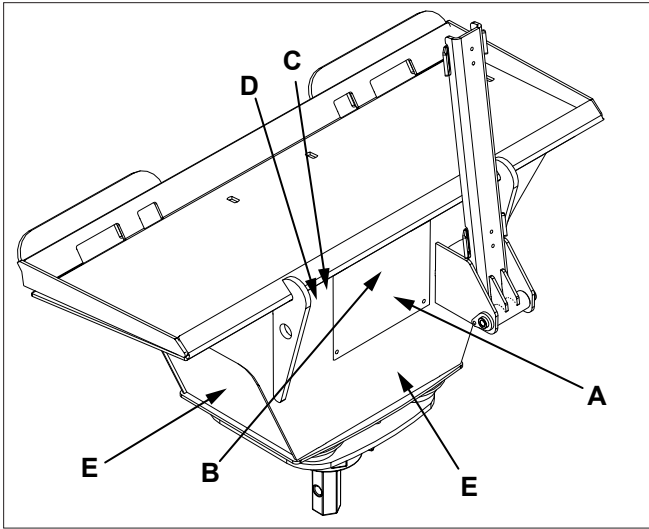
If any of the decals are missing, are damaged, or if you do not understand the decal, please contact your dealer.



- A. D005262  WARNING - P65 warning information.

 **WARNING:** This product can expose you to chemicals including 1,3-Butadiene and lead, which are known to the state of California to cause cancer and birth defects or other reproductive harm. For more information go to www.P65Warnings.ca.gov.

D005262

- B. D005126  WARNING - Pressurized fluid hazard. Keep away from machine.



C. D005517 ⚠ WARNING - Remove key before servicing.

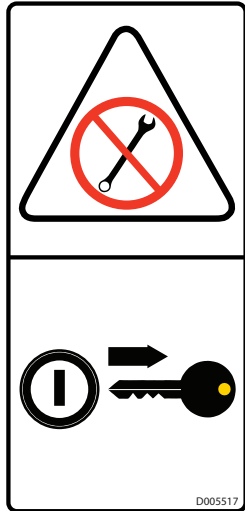

D. D005125 ⚠ WARNING - Read and understand safety signs on the machine and operating instructions in this manual before operating machine.

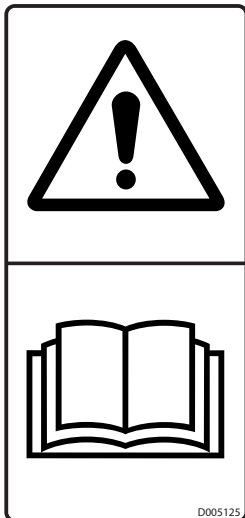

E. D005128 ⚠ WARNING - Rotating auger hazard. Keep back while machine is operating.





3.3 Safety Signs - RSS780

The two and four panel safety decals are pictorial and have a yellow background. The panel with a triangle indicates the potential hazard. The panel without a triangle indicates how to avoid the hazard.

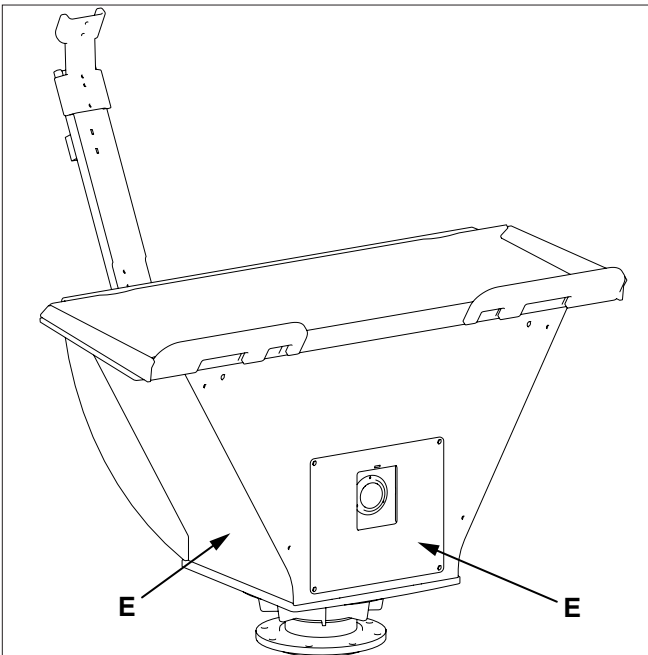
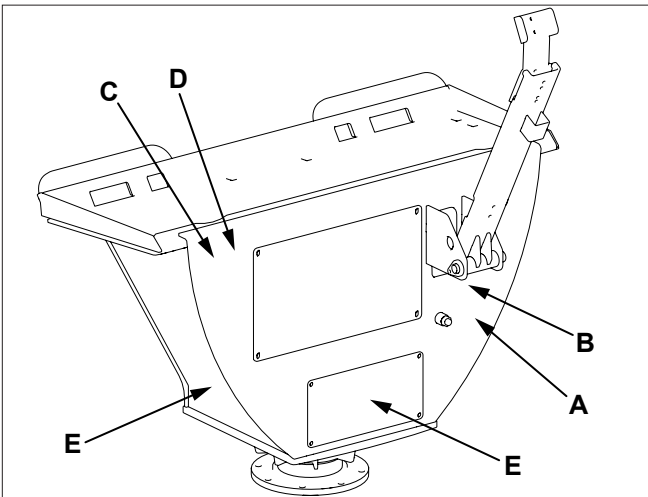
If any of the decals are missing, are damaged, or if you do not understand the decal, please contact your dealer.



A. D005262  WARNING - P65 warning information.

 **WARNING:** This product can expose you to chemicals including 1,3-Butadiene and lead, which are known to the state of California to cause cancer and birth defects or other reproductive harm. For more information go to www.P65Warnings.ca.gov.

D005262

B. D005126  WARNING - Pressurized fluid hazard. Keep away from machine.



C. D005517 ⚠ WARNING - Remove key before servicing.

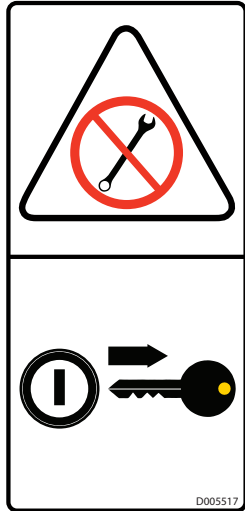

D. D005125 ⚠ WARNING - Read and understand safety signs on the machine and operating instructions in this manual before operating machine.

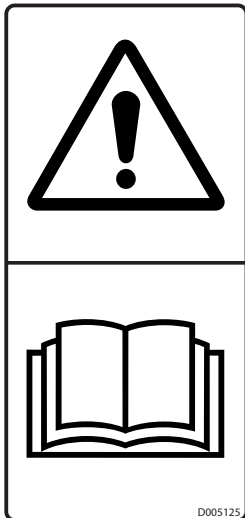

E. D005128 ⚠ WARNING - Rotating auger hazard. Keep back while machine is operating.



4 OPERATION

4.1 Machine Components

- A. Skid Steer Quick Attach Mounting Plate
- B. Hydraulic Hose Holder
- C. Hydraulic Motor
- D. Vibro-Isolator Rubber Mounts*
- E. Gearbox Shaft

* The rubber mounts help to soften the impact and side leverage on the drive shaft and are also designed to fail to help protect the drive shaft from breaking.

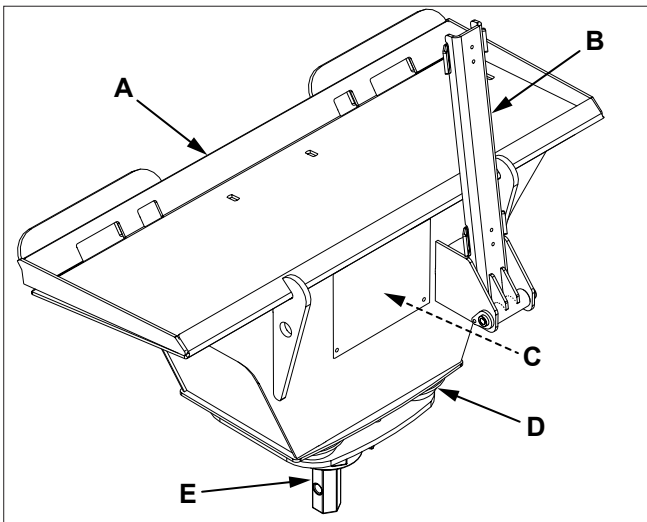

4.2 Preparation for Use

Although the Splinter has been carefully inspected and checked prior to shipment from manufacturer, it is recommended that the unit be thoroughly inspected.

Check all bolts for tightness and remove all shipping tags, bags, skids, and blocking.

Remove any masking materials affixed during painting. Inspect equipment to verify that nameplates and all safety warning, caution signs and decals provided with the equipment are in place and clearly visible.

Visually inspect the Splinter before each start up. Check for loose or missing parts and any damage that may have occurred during moving or shipping.

Review all skid steer pre-start instructions, and verify that all recommended steps and procedures have been followed.

4.3 Hydraulic Connections



WARNING

Pressurized fluids can penetrate the skin.

Disconnect and lock out power source before disconnecting and/or connecting hydraulic hoses.

The RSS Splinters come equipped with pressure hose, return hose and a case drain hose installed.

Connect 1/2 in. pressure hose, 1/2 in. return hose to skid steer pressure and return couplers.

The RSS780 must have the case drain hose connected to the skid steer return to sump/reservoir coupler.

The RSS380 and RSS580 can operate without case drain if hydraulic pressure is under 2500 psi (17237 kPa). If hydraulic pressure is near or may exceed 2500 psi (17237 kPa), connect case drain hose on Splinter to skid steer return to sump/reservoir coupler.

Starting with model year 2022, models that require a case drain will be equipped with a zero leak relief valve plumbed into the T fitting on the motor case drain port.

If the case drain line is not connected or becomes obstructed, the zero leak relief valve will vent the pressurized hydraulic fluid to the atmosphere, protecting the motor from damage.

The zero leak relief valve will self reset after hydraulic pressure in the case drain line is reduced. Do not alter the plumbing circuit to the zero leak relief valve.

Note: *Side covers have been removed for illustration purposes only. Do not operate with covers removed.*

4.4 Attach To Skid Steer

WARNING

To prevent injury or machine damage put transmission in “Park”.

Never position yourself between skid steer and Splinter.

Only experienced and properly trained operator’s should operate skid steer and Splinter.

1. Read and follow all safety instructions.
2. Attach skid steer to Splinter. See skid steer Operator’s Manual.
3. Connect hydraulic hoses. Verify hydraulic hoses are clear of pinch areas and moving parts.
4. Move to a clear open area to test functions.

4.5 Attachments

WARNING

Prevent serious injury or death caused by unexpected movement:

1. Park on a level surface.
 2. Lower Splinter close to ground.
 3. Engage parking brake.
 4. Shut off engine and remove key.
1. Attach splinter screw or planer to gearbox.

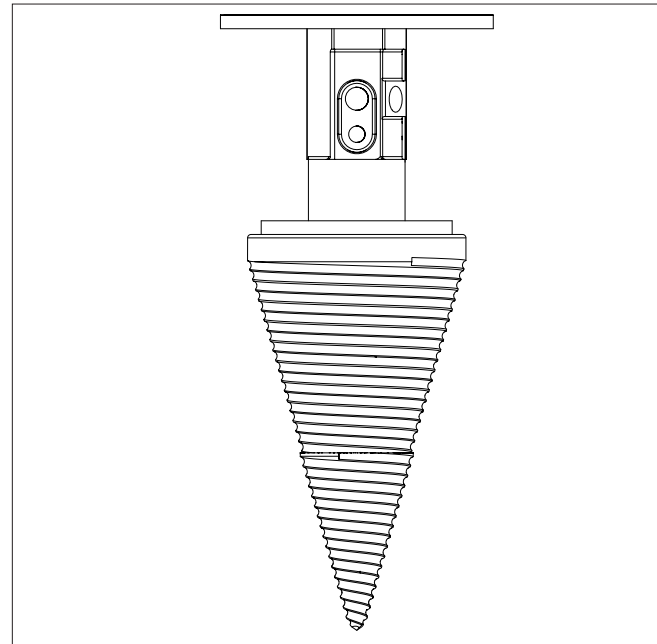

Splitter Screw

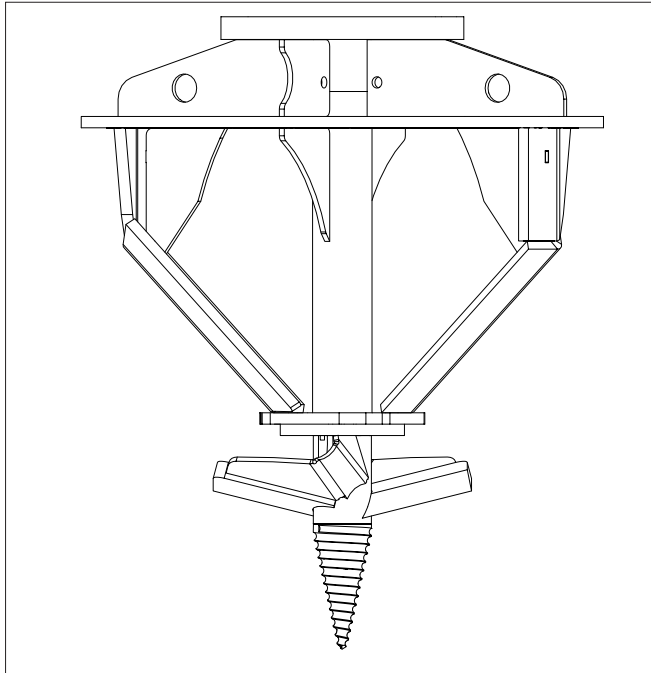

Planer

4.6 Transporting

1. Verify all reflectors and Slow Moving Vehicle (SMV) sign are visible.
2. Verify hydraulics to Splinter are disengaged.
3. Raise Splinter slightly off the ground.
4. Travel at a reasonable and safe speed.

4.7 First Time User Tips

Operate all functions in a clear area at low speed to get a good feel for the controls.

Move Splinter into wood slowly until you have a better feel how much the unit can take.

Each operator must experiment to find a technique that works for them in their application.

WARNING

Always stop engine and remove key before leaving operators seat.

4.8 Field Operation

WARNING

Prevent serious injury or death caused by unexpected movement:

1. **Park on a level surface.**
2. **Lower Splinter to ground.**
3. **Engage parking brake.**
4. **Shut off engine and remove key.**

WARNING

Keep shields and guards in place at all times. Do not operate without shield and guards.

Do not wear loose fitting clothing.

WARNING

Never operate Splinter when other people are in the vicinity.

Debris can be thrown from cutting area.

Do not allow riders.

WARNING

Clean machine thoroughly before service or maintenance procedures.

The health effects from exposure to wood dust are due to chemicals or chemical substances in the wood created by bacteria, fungi, or molds.

Inspect work area to verify there are no rocks, metal or other debris before cutting.

Attach Splinter to skid steer.

Splitter Screw Operation

1. Set engine speed to low idle and engage hydraulics.
2. Verify splitter is turning in forward direction.
3. Slowly increase engine speed to high idle.
4. Verify splitter is operating smoothly and move splitter into log.
5. Slowly push splitter into wood. If wood does not split, reverse hydraulic flow to back splitter out of wood.
6. Move to another location and repeat step 4-5.



Planer Operation

1. Set engine speed to low idle and engage hydraulics.
2. Verify planer is turning in forward direction.
3. Slowly increase engine speed to high idle.
4. Verify planer is operating smoothly and move planer into stump.

Note: Beginning from the center of a large stump will leave a ridge around the outer edge that will not allow the blades to cut efficiently, and will end up breaking off chunks.

5. When positioning the planer on a stump that is larger than the large blade diameter, It is important to begin cutting from one side, rather than center. Begin at one side, shearing down to the desired level.

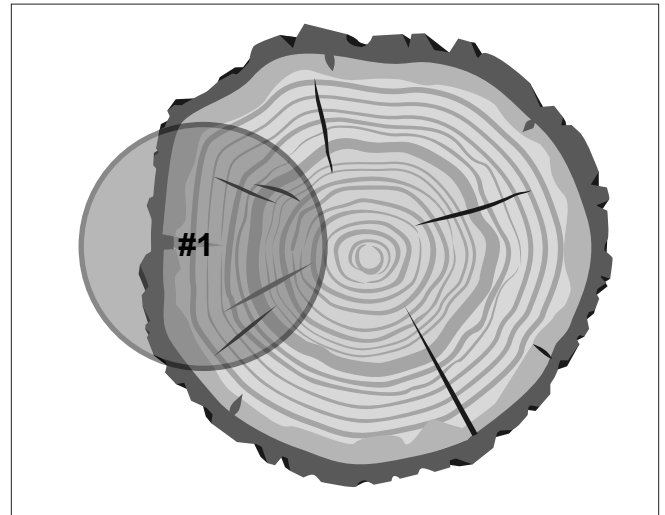

1. Move around the perimeter, ensuring that there are no outer ridges being left behind.
2. Once the center area is smaller than the diameter of the large blades, a center cut can be made to finish the job.

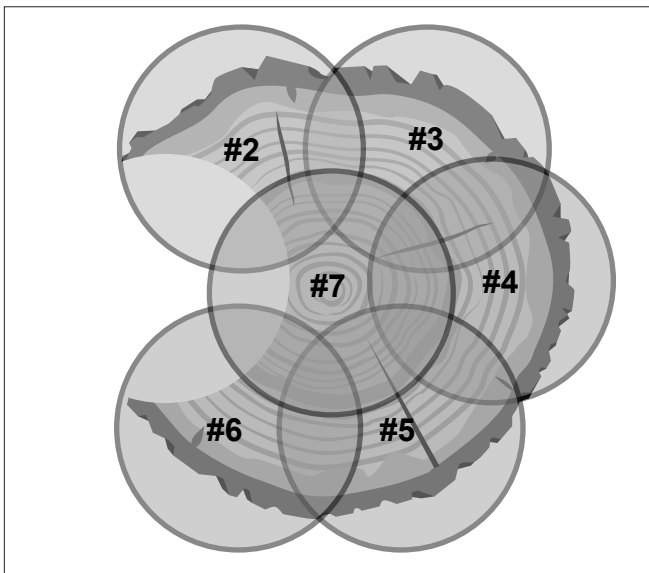

! WARNING

Moving parts can crush and cut.

Keep clear of moving components.

Lockout skid steer before clearing jams.

3. If planer stalls, stop movement, raise slightly and allow planer to regain speed. Slow movement into stump to prevent further stalling.

4.9 Detach From Skid Steer

! WARNING

Prevent serious injury or death caused by unexpected movement:

1. Park on a level surface.
2. Lower Splinter to ground.
3. Engage parking brake.
4. Shut off engine and remove key.

1. Park skid steer on a level surface.
2. Lower Splinter to the ground and lay on side.
3. Shut off engine and remove key.
4. Disconnect hydraulic hoses.
5. Detach skid steer from Splinter. See skid steer Operator's Manual.

5 SERVICE AND MAINTENANCE

5.1 Daily

WARNING

Prevent serious injury or death caused by unexpected movement:

1. Park on a level surface.
2. Lower Splinter to ground.
3. Engage parking brake.
4. Shut off engine and remove key.

Inspect the unit for buildup of dirt and debris. Clean out as needed.

5.2 Motor Shaft Seal - RSS780 Only

To prevent hydraulic motor damage, the motor shaft seal is designed to fail if case pressure exceeds 100 psi (689 kPa).

If motor shaft seal (A) has failed, verify case drain line is free flow to sump or reservoir. Also check drain line for blockage. Correct any problems before replacing shaft seal.

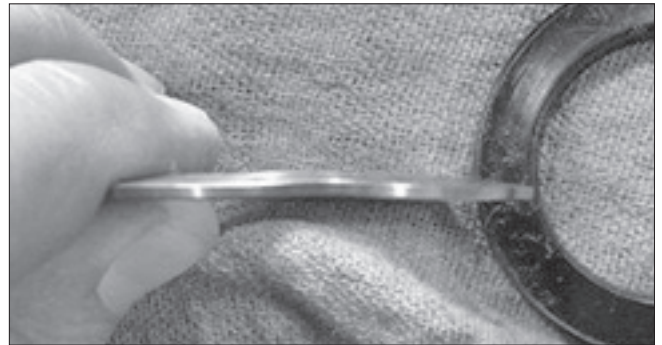

Over-Pressurized Damaged Washer (B)

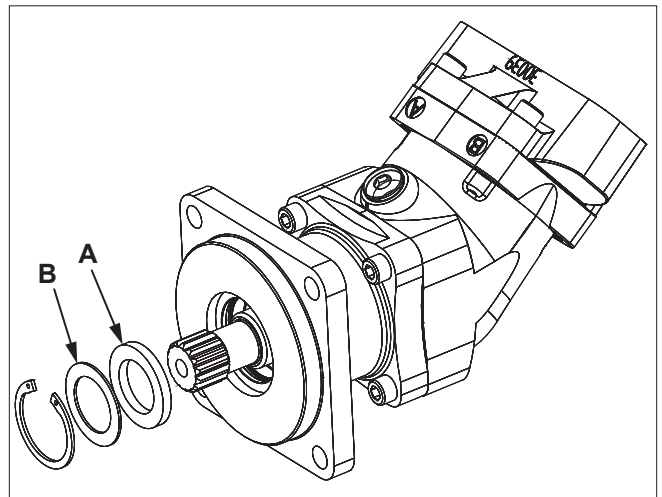

Order replacement seal kit from Baumalight and follow instructions provided with kit.

Motor Shaft Seal Replacement manual can be found at www.baumalight.com/support

Note: Parts breakdown can be found on Baumalight's website. www.baumalight.com

5.3 Zero Leak Case Drain Relief - RSS780 Only

The machine is equipped with a case drain port. If a case drain hose is required or recommended, you must connect a case drain hose to the case drain port and route to the skid steer hydraulic reservoir.

It is normal for a hydraulic motor to have a slight amount of internal leakage.

The case drain line will allow this internal leakage to be returned to the reservoir, preventing excessive pressure on the motor seal.

Starting with model year 2022, splinters and planers (if required) will be equipped with a zero leak relief valve installed in the case drain line.

If the case drain line is not connected or becomes obstructed, the zero leak relief valve will vent the pressurized hydraulic fluid to the atmosphere. The zero leak relief valve will self reset after hydraulic pressure reduced.



WARNING

Pressurized fluids can penetrate the skin.

Keep bystanders away from machine during operation.

A tiny, almost invisible leak can penetrate the skin, thereby requiring immediate medical attention.

If hydraulic fluid is coming out of the zero leak relief valve, shut down machine immediately. Inspect the case drain line connection and lines. Contact your dealer if case drain lines and connection are good.

NOTICE

Environmental hazard.

Clean up any spilled hydraulic fluid immediately.

A properly installed case drain protected by a zero leak relief valve will save the work of replacing the motor shaft seal and also improve the efficiency of your hydraulic system.

6 TROUBLESHOOTING

PROBLEM	CHECK	SOLUTION
Bit does not spin.	Bit jammed.	Remove material from bit.
	Verify hydraulic hoses are connected.	Connect hoses.
Skid steer is not able to lift Splinter.	Skid steer is too small.	Use proper size skid steer.

7 STORAGE

7.1 Storing Splinter

1. Store Splinter in a dry place.
2. Clean Splinter thoroughly. Dirt and wood chips will draw moisture and cause rust.
3. Check for loose or missing hardware.
4. Paint parts as necessary.

7.2 Remove From Storage

1. Review Operator's manual and check adjustments.
2. If parts have been replaced, verify they run properly.

BAUMALIGHT ATTACHMENT WARRANTY

The product is warranted to be free of defects in materials and workmanship under normal use and service, for a period of one year from the date of purchase. This warranty covers parts and labor, but does not cover misuse, negligence, dealer travel time and shipping costs to and from the dealer.

Replacement of individual parts vs. assemblies are at the discretion of the manufacturer.

Warranted replacement parts will be shipped to the customer free of charge via ground shipping. If expedited shipping requested, the customer will be charged the difference between ground shipping and the cost of expedited shipping. Damage in transit is not covered by warranty.

Baumalight products purchased new must be registered for warranty at <https://baumalight.com/support/product-registration>.

Warranty claims must include the original bill of sale. This warranty is extended only to the original purchaser and there is never any warranty on anything sold through auction.

This product must be operated and maintained in accordance with the Operating and Maintenance Instructions supplied with this unit.

Under no circumstances will the manufacturer be liable for any consequential damage or expense of any kind, including loss of profits. The manufacturer is under no circumstances liable for carrier unit damage of any kind. The manufacturer is not liable for the maintenance of the product. Baumalight will not cover time to diagnose and repair compatibility issues between carrier and attachment.

When receiving a shipment from the manufacturer:

1. Compare items received with the carriers bill of lading.
2. Check for damage before signing for the shipment. If damage is found, note damage on carriers bill of lading and photograph the damage.

Warranty repairs may be done by the end user if the end user is willing and capable.

The Manufacturer's Liability is limited to repair of the product and/or replacement of parts and is given to the purchaser in lieu of all other remedies including incidental and consequential charges. There are no warranties, expressed or implied other than those specified herein. For the nearest Authorized Service Center call the manufacturer.

The allowable time for dealers to perform some repairs can be found on our website in the support section under Service And Instruction Videos & Support. If website does not list a time for the repair, dealer must contact the manufacturer before starting the repair to find how much time will be covered for the activity. The manufacturer will only cover up to 1 hour to diagnose and troubleshoot an issue, regardless of the suggestions recommended by the manufacturer to check and verify an issue.

Model Number: _____ S/N: _____

Date of Purchase: _____ Owner's Name _____

Replacement parts sold after the equipment warranty has expired are warranted for a period of 30 days from the date of purchase. Labor, diagnosis and troubleshooting are not covered on replacement parts.

For parts, specifications and the latest machine information please visit our website.

www.baumalight.com

MTB MFG INC.
CORPORATE HEADQUARTERS
4575 Powell Rd.,
Wallenstein, Ontario Canada
N0B 2S0
Phone - 519.698.9864
www.baumalight.com

