

# 2025

## DEALER PROGRAMS



### **ATTACHMENTS**

FOR SKIDSTEER  
EXCAVATOR & TRACTORS



# **DEALER SUPPORT**

# **PROGRAMS**

# 2025 ONLINE DEALER SUPPORT PROGRAM

## Standard Dealer Portal Listing

SOLD BY  
EQUIPMENT DEALERS  
FOR LOCAL SUPPORT

- Dealer Portal Username and Password
- Dealer Portal login access to price lists and PDF literature
- We advertise for the Dealer by displaying them on our dealer locator

## “Star Dealer” Dealer Portal Listing



- All of the above
- Dealer ‘Star’ indication to make them stand out in the crowd
- This can be turn on by your rep with no other obligations

## Extra Cash Discount - Promote Baumalight for a Higher Cash Discount

We are willing to give dealers who help promote brand recognition extra cash discount. Standard cash discount is **5%** in most areas but depending what you are willing to do we will give more. **You are not required to be a Star Dealer but the more of the following list you hit, the more your cash discount could be for the rest of the year.**

### Ways to Gain More Cash Discount:

- 1. In-store Baumalight brand recognition** (the more you have the greater your discount)
  - Banner
  - Poster
  - Catalogs
- 2. On-line Branding - Show Baumalight logo with links to our website**
- 3. On-line Product Presence - Feature up-to-date Baumalight products on your website**
- 4. Dealer Profile completely filled out on Baumalight On-line Dealer Portal**
- 5. Previous year’s level of sales**
- 6. Print and Digital Ads (the more you have the greater your discount)**
  - Show Baumalight logo in existing ad strategy
  - Dedicated Baumalight co-op ads
  - Link to Baumalight website from social media
  - Feature Baumalight videos
  - Baumalight link or logo in email signatures

### Requirements:

- Approval from Menno, Territory Managers are not allowed to make any promises
- Email conversation with Menno required to test responsiveness
- The additional cash discount will only be available on new invoices after completion, not anything that is invoiced before or during discussions
- Annual reassessment

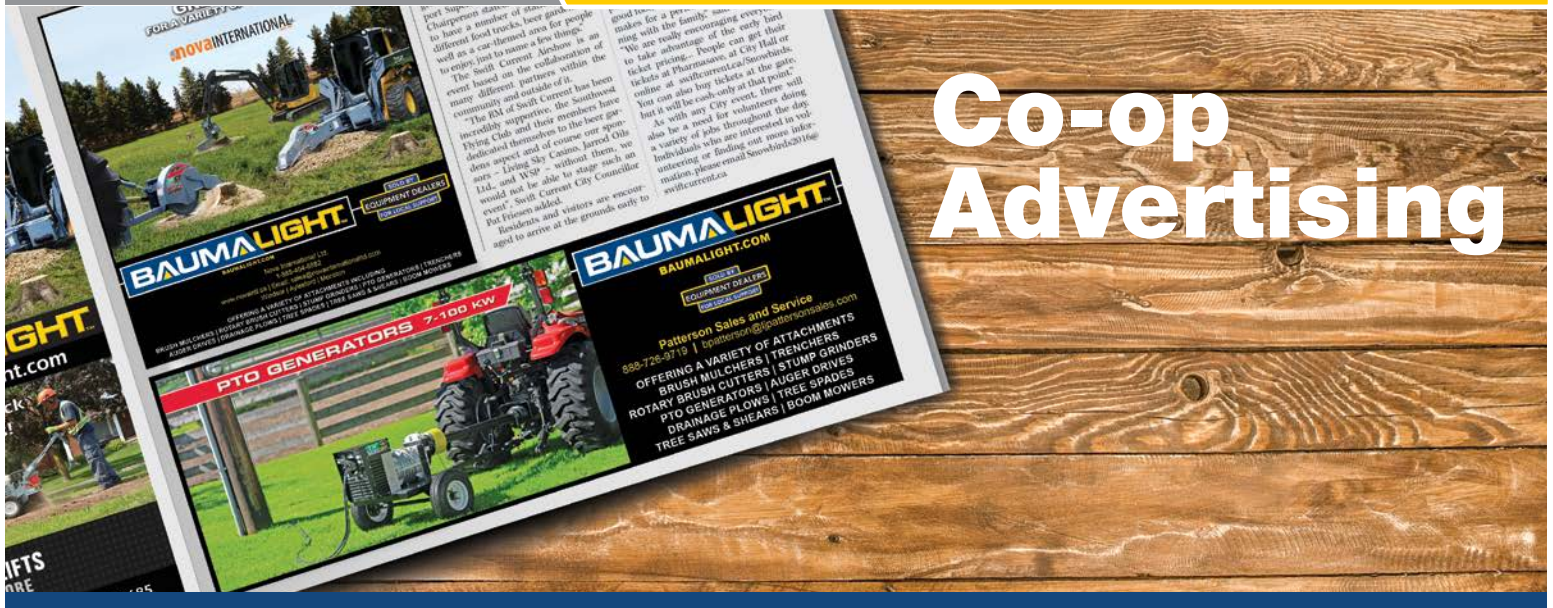

For more exposure, MTB MFG offers to share advertising costs for Baualight products on a 50% co-op as follows (with prior authorization).

**Eligible Advertising**

- 1.** News Paper Display Ads
- 2.** News Letters
- 3.** Direct Mailings
- 4.** Booth Spaces (Will cover 100% of the cost of the area used for Baualight)
- 5.** Social Media

Note: BAUMALIGHT WILL BE HAPPY TO DO ALL THE WORK TO CREATE ADS.

**Requirements:**

- 1.** Baualight logo must be shown on ad.
- 2.** Reimbursement is for ad/show space on Baualight products only.
- 3.** Send a copy of paid bill and tear-sheet/photos of booth.
- 4.** Ad/booth space used for dealer info and other products are not considered Baualight ad space.

**Reimbursement:**

Reimbursement is available as a credit on account only to be used towards the purchase of new Baualight product. The dealer will pay the advertiser in full. Co-op advertising spend also helps towards the available Extra Cost Discount for promoting Baualight.

# BAUMALIGHT ATTACHMENT STOCKING DEALER PROGRAM

Same as 2024, in 2025 we offer the program in two 6-month booking periods to make it easier to get in with a booking deadline in January and again in July. The new program will only apply to whole good orders and we are still working on a new parts order discount program.

To activate the Stocking Dealer Program, simply place a stock order for whole goods in the timeframe listed below.

Based on the value of your current paid stock, plus the value of the new stocking order, you will then receive the appropriate additional discount for the remainder of the 6-month booking period.

**Another change we are making for 2025 is that only some dealers will be eligible for longer terms, this will be decided on a case by case bases.**

**2025**  
**BOOKING**  
**CUT-OFFS**  
**JANUARY 18**  
**JULY 12**

List	Dealer Net	Min. # of Whole Goods	Winter Booking Start Date	Booking End Date	Ship Dates	Discount	Due Date & Discount end date
\$20,000	\$16,000	3	Dec 1, 2024	Jan 18, 2025	Approx 1 month after date of order	4%	June 30, 2025
\$30,000	\$24,000	4	Dec 1, 2024	Jan 18, 2025	Approx 1 - 2 months after date of order	5%	June 30, 2025
\$45,000	\$36,000	5	Dec 1, 2024	Jan 18, 2025	Approx 1 - 2 months after date of order	6%	June 30, 2025

List	Dealer Net	Min. # of Whole Goods	Summer Booking Start Date	Booking End Date	Ship Dates	Discount	Due Date & Discount end date
\$20,000	\$16,000	3	June 1, 2025	July 12, 2025	Approx 1 month after date of order	4%	Dec 31, 2025
\$30,000	\$24,000	4	June 1, 2025	July 12, 2025	Approx 1 - 2 months after date of order	5%	Dec 31, 2025
\$45,000	\$36,000	5	June 1, 2025	July 12, 2025	Approx 1 - 2 months after date of order	6%	Dec 31, 2025

1. Payment terms are due when the attachments are sold or on due dates specified above, whichever comes first.
2. The discount achieved would apply to all Baumalight whole good orders except mini skidsteers for the next booking period. Parts orders no longer get a stocking dealer discount but we are coming out with new parts order programs.
3. Paid inventory is eligible for minimum quantity requirements, but must be new and have been purchased within 12 months to qualify.
4. Auger drives and bits are not eligible for Stock & Save minimum piece order requirements (See Auger Drive Booking Program for separate booking order discount structure for Auger Drives and parts).
5. Tree Scoops and Tree pullers also do not qualify as whole goods to help you qualify for this program. However, once qualified, they will receive the discount for future orders.
6. Must make a new purchase, and everything must be ordered to ship in one shipment to one address.
7. No urgent delivery requests allowed, if you need something quick then another order must be placed.
8. Mini Skidsteers are on a separate program, but stocking 2 or more mini skidsteers will automatically qualify you for one of the above discounts, see complete details under mini skidsteer program
9. The Stock & Save discounts are only available direct to dealer, and not available through distributors. This allows us to have a lower list price which benefits everyone.
10. Terms will only be offered to some dealers and will be decided on a case by case bases



# AUGER DRIVE PROGRAM

(ORDERS INTENDED FOR DISPLAY)

Separate from our Stock & Save Program, we also offer an Auger Bit and Drive Program. Order stock of Auger Bits & Drives between December 1, 2024 and January 28, 2025 and based on the value of your stocking orders, you will receive an additional discount on auger drives, bits, extensions, adapters and accessories ordered before December 31, 2025.

## 6% Discount Program

Show Baumalight on Dealer website

6% Extra discount for rest of year on all drives, bits, extensions, adapters and accessories

Booking Start Date	Booking End Date	Ship Dates	Discount	Due Date	Price*
December 1st 2024	Jan 28 2025	Approx. 1- 2 months after date of order	6%	July 31, 2025	\$9,550.00

## 9% Discount Program

Show Baumalight on Dealer website

9% Extra discount for rest of year on all drives, bits, extensions, adapters and accessories

Booking Start Date	Booking End Date	Ship Dates	Discount	Due Date	Price*
December 1st 2024	Jan 28 2025	Approx. 1- 2 months after date of order	9%	July 31, 2025	\$12,000.00

## 14% Discount Program

Show Baumalight on Dealer website

14% Extra discount for rest of year on all drives, bits, extensions, adapters and accessories

Booking Start Date	Booking End Date	Ship Dates	Discount	Due Date	Price*
December 1st 2024	Jan 28 2025	Approx. 1- 2 months after date of order	14%	July 31, 2025	\$22,000.00

July 31, 2025 Standard Cash Discount.

If item sells prior to July 31, 2025, dealer agrees to pay on sale.

\*List price value of total order.

Must be shipped in one lot.

2025 pricing in affect.

The Stock & Save discounts are only available direct to dealer, and not available through distributors. This allows us to have a lower list price which benefits everyone.

Extra Discount on bits, drives and auger accessories for rest of calender year on all drives, bits, extensions, adapters and accessories.

Not eligible with any other program except the extra cash discount.



D001753 - \$350 List, \$50 With Order

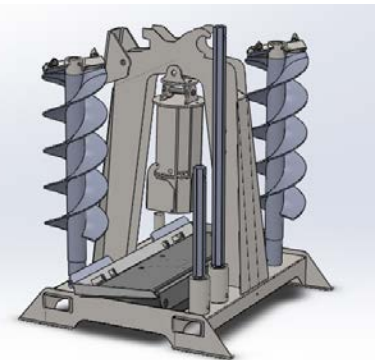

D002107 - \$1,450 List, \$850 With Order

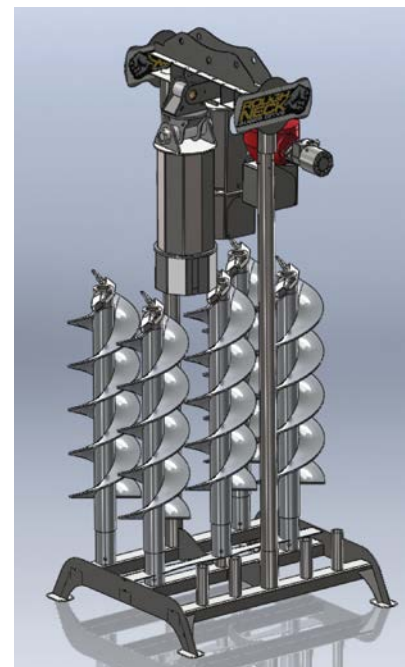

D001596 - \$3,500 List, \$1,500 With Order



# Flexible interest-free floorplan financing programs for Baumatic dealers

## Gain a competitive advantage and sell more product with DLL

Baumalight and DLL Canada have partnered to provide flexible floorplan solutions allowing dealers to stock inventory, sell quicker and grow the business. With DLL, you can put all Baumatic equipment and attachment purchases on one line of credit and match repayment to the sale of goods, improving cash flow and simplifying payment management.

DLL is a wholly owned subsidiary of the Rabobank Group and has over 50 years of experience on the manufacturing, distributor, and dealer sides of the business. As partners, we're committed to not only providing relevant financing solutions, but also building long-term relationships.

In addition to floorplan finance, DLL is pleased to offer dealers total financing solutions, including retail and end-user leasing programs.

### How it works

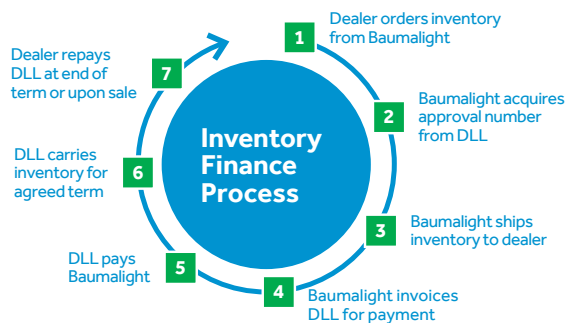

*\*This financing program is only available to fully established Baumatic dealers who have shown a strong payment history. Contact Baumatic to see if you qualify.*

### Benefits to you

- **Higher credit line** and increased purchasing power
- **Extended payment terms** to match the sale of goods
- **Improved cash flow** management
- **Ability to sell more product** with total inventory and retail finance
- **Dedicated credit line** with reduced credit exposure
- **Preserve existing bank lines** for other strategic initiatives
- **Faster** customer delivery



### How to apply

Contact Surjeet Soor at [surjeet.soor@dllgroup.com](mailto:surjeet.soor@dllgroup.com) to request a credit application.

## For more information

**Surjeet Soor**  
Business Development Manager, DLL  
E [surjeet.soor@dllgroup.com](mailto:surjeet.soor@dllgroup.com)  
T 437 218 3342

**Ryan Brooks**  
Purchasing, Baumatic  
E [ryan@baumalight.com](mailto:ryan@baumalight.com)  
T 866 820 7603

5046 Mainway  
Unit 1  
Burlington, ON L7L 5Z1

[www.dllgroup.com/commercialfinance](http://www.dllgroup.com/commercialfinance)

\*Interest-free period varies by dealer and is subject to review from Baumatic.

\*\*All financing subject to credit review and approval and other terms and conditions. All financing is in DLL's sole discretion.

© DLL - De Lage Landen International B.V. DLL® and DLL Financial Solutions Partner<sup>SM</sup> are registered service marks of De Lage Landen International B.V. 10/22  
All other copyrights and trademarks belong to their respective owners.

