



# BAUMALIGHT

## LIGHT INDUSTRIAL EQUIPMENT

NEW: All pricing is now online only at [www.baumalight.com](http://www.baumalight.com)

### PRODUCTS FOR TRACTORS. SKIDSTEERS AND EXCAVATORS

Augers  
Boom Mowers  
Brush Mulchers  
Feller Bunchers  
Generators

Rotary Brush Cutters  
Screw Splitters  
Stump Grinders  
Stump Planers  
Tile Drainage Plows

Tree Saws  
Tree Shears  
Tree Spades  
Trenchers

# NEW FOR 2022

CHECK INSIDE FOR FULL DETAILS ON THESE EXCITING NEW PRODUCTS!

## NEW!

### Online Motor Option Calculator

Online tool to easily find the right Baumalight product and motor option for your carrier.

[baumalight.com/motor-option-calculator](http://baumalight.com/motor-option-calculator)



### Now Available! Two-Speed Motor

Our new Two-Speed Motor is now an available upgrade on all 900 and 1100 series Brush Mulchers. You can now maximize your rotor speed and torque to account for changing mulching material.

### All pricing is now online only.

For all Baumalight product and wear part pricing, please visit [baumalight.com](http://baumalight.com) and click Contact, then How to Buy. Be sure to confirm your currency, then search for your product.



### MP972 BRUSH MULCHER



84" Path Width  
AR400 Steel Wear Shields

### DXD752 TREE SAW



360° Slew Drive Rotation  
25 to 60 gpm motor

# TABLE OF CONTENTS

<b>Teeth Options .....</b>	<b>4</b>
<b>Augers.....</b>	<b>6</b>
<b>Trenchers .....</b>	<b>12</b>
<b>Tree Spades .....</b>	<b>14</b>
<b>Holt Industrial Tree Spades .....</b>	<b>18</b>
<b>Generators .....</b>	<b>22</b>
<b>Stump Grinders .....</b>	<b>28</b>
<b>Screw Splitters.....</b>	<b>38</b>
<b>Stump Planers.....</b>	<b>38</b>
<b>Tree Shears .....</b>	<b>40</b>
<b>Tree Saws .....</b>	<b>44</b>
<b>Feller Bunchers .....</b>	<b>50</b>
<b>Rotary Brush Cutters .....</b>	<b>52</b>
<b>Boom Mowers .....</b>	<b>58</b>
<b>Brush Mulchers .....</b>	<b>60</b>
<b>Tile Drainage Plows .....</b>	<b>74</b>
<b>Excavator Mounting .....</b>	<b>78</b>

**NEW: All pricing is now online only at [www.baumalight.com](http://www.baumalight.com)**

# TEETH OPTIONS

Visit [baumalight.com](http://baumalight.com) for all replacement teeth and wear part options.



**F2000**  
Flail Tooth



**F3000 (Sold Individually)**  
Flail Tooth



**S1000**  
Planer



**P5000**  
Planer



**R9000**  
Ripper



**T9000**  
Planer (holder sold separate)

\*GeethTeeth® and Wearsharp® are trademarks of Green Manufacturing, Inc.

**NEW: All pricing is now online only  
at [www.baumalight.com](http://www.baumalight.com)**

**FREE**  
WITH NEW PURCHASE  
OF WHOLE GOODS  
SEE ONLINE FOR DETAILS



**G3000\***  
GreenTeeth®



**W3000\***  
Wearsharp®



**H3000**  
High Speed



**R5000**  
Ripper



**R7000**  
Ripper



**P11000**  
Planer



**B8000**  
Beaver (holder sold separate)

# AUGERS

OWNER OPERATOR & CONTRACTOR



## PRODUCT FEATURES

- Variety of mounting options, drive sizes and shapes
- Many available bits, adapters and extensions
- Single bolt-on bit design for quick bit changes
- Universal joint for strength and self-leveling
- Quick lead-time and free shipping
- Optional hydraulic hoses with flat-faced couplers

Visit [baumalight.com](http://baumalight.com) for additional product information and product videos.

# OWNER OPERATOR SERIES



SOLD BY  
EQUIPMENT DEALERS  
FOR LOCAL SUPPORT



## RC442 - 2" Round Drive

6-14 Rec. GPM to 18 Max. GPM  
Gear drive  
1" pivot pins  
Standard frame  
Skidsteer size: 1500 - 5000 lbs  
Excavator size: 2000 - 4000 lbs  
3.18:1 gear ratio  
98 lbs. shipping weight (drive only)  
Adapter code: A



## RC582 - 2" Hex Drive

6-24 Rec. GPM to 25 Max. GPM  
Planetary drive  
1" pivot pins  
Standard frame  
Skidsteer size: 1500 - 6000 lbs  
Excavator size: 2000 - 6000 lbs  
3.6:1 gear ratio  
124 lbs. shipping weight (drive only)  
Adapter code: B



### RC442 Flow Chart

■ RPM ■ Foot Pounds Torque

GPM	1,000 PSI		1,250 PSI		1,500 PSI		1,750 PSI	
6	52.5	305	51.3	380	49.4	407	47.8	540
10	88.1	293	86.5	368	84.3	441	81.8	521
14	125.2	274	123.3	352	121.4	425	118.9	497
16	146.2	249	145.3	328	143.4	399	140.6	485

On low flows torque is more important than speed

### RC582 Flow Chart

■ RPM ■ Foot Pounds Torque

GPM	1,500 PSI		2,000 PSI		2,500 PSI		3,000 PSI	
6	29.4	757	28.3	1,028	26.4	1,290	23.3	1,538
10	50.6	734	48.9	1,004	46.4	1,272	41.7	1,529
16	82.2	678	80.3	944	75.8	1,207	71.4	1,479
20	103.3	630	101.4	893	96.7	1,160	91.9	1,426
22	113.9	602	111.9	866	106.9	1,135	102.2	1,400
24	124.7	572	122.5	837	117.5	1,108	112.5	1,374

# CONTRACTOR SERIES



## RC586 - 2" Hex Drive

10-24 Rec. GPM to 25 Max. GPM  
Heavy duty planetary drive  
1 1/2" pivot pins with brass bushings  
Heavy duty frame  
Skidsteer size: 2000 - 8,000 lbs  
Excavator size: 3000 - 20,000 lbs  
6:1 gear ratio  
158 lbs. shipping weight (drive only)  
Adapter code: D



## RC780 - 2" Hex Drive

20-40 Rec. GPM to 45 Max. GPM  
Heavy duty planetary drive  
1 1/2" pivot pins with brass bushings  
Heavy duty frame  
Skidsteer size: 3000 - 12,000 lbs  
Excavator size: 4000 - 30,000 lbs  
5:1 gear ratio  
460 lbs. shipping weight (drive only)  
Adapter code: D

If you order a hose kit, a case drain hose is included (case coupler not included)



## WHY HEX DRIVE?

With a round auger drive, in time the cross pin can wear and the torque can cause the pin holes to warp. With a hex auger drive, you get 6 flat surfaces driving the auger, allowing for greater torque and a longer life.

Prices do not include mounting plate, see mounting plate page for mounting options. Additional Contractor Series models are available online at [baumalight.com](http://baumalight.com).

### RC586 Flow Chart

■ RPM ■ Foot Pounds Torque

GPM	1,500 PSI		2,000 PSI		2,500 PSI		3,000 PSI	
6	17.7	1,262	17.0	1,713	15.8	2,150	14.0	2,564
10	30.3	1,223	29.3	1,673	27.8	2,120	25.0	2,549
16	49.3	1,130	48.2	1,573	45.5	2,011	42.8	2,465
20	62.0	1,050	60.8	1,489	58.0	1,934	55.2	2,377
22	68.3	1,004	67.2	1,444	64.2	1,892	61.3	2,333
24	74.8	954	73.5	1,395	70.5	1,847	67.5	2,291

### RC780 Flow Chart

■ RPM ■ Foot Pounds Torque

GPM	2,000 PSI		2,500 PSI		3,000 PSI		3,500 PSI	
20	44.8	2,294	42.8	2,870	39.8	3,447	36.4	4,006
24	54.1	2,289	51.5	2,879	49.1	3,463	45.9	4,023
28	63.4	2,281	61.0	2,870	58.4	3,459	54.1	4,006
32	72.9	2,243	70.1	2,841	67.5	3,438	63.4	3,973
40	90.3	2,167	87.3	2,769	84.6	3,375	79.8	3,880

# AUGER BITS



## AGGRESSOR AUGERS - 30"

2" SHAFT	DIMENSIONS DIAM. X LEN.	WEIGHT (LBS.)
137140	6" x 30"	35
137141	9" x 30"	39
137142	12" x 30"	47



137142

## AG AUGERS

2" SHAFT	DIMENSIONS DIAM. X LEN.	WEIGHT (LBS.)
553228	6" x 48"	40
553229	9" x 48"	60
553230	12" x 48"	65



553229

## AGGRESSOR AUGERS - TREE AUGER

2" SHAFT	2-9/16" SHAFT	2" HEX	DIMENSIONS DIAM. X LEN.	WEIGHT (LBS.)
103785	135532	135533	4" x 48"	39
135578	135542	135554	18" Tree Auger	150
135579	135543	135555	24" Tree Auger	175
135580	135544	135556	30" Tree Auger	240
135581	135545	135557	36" Tree Auger	315



135555



103785

4" Augers have a Special Pilot Tip (#133407)



## BOLT-ON ROCK HEAD (replaces teeth and pilot bit)

	DIMENSIONS	WEIGHT
137991	6-BOR kit 6"	24
137992	9-BOR kit 9"	36
137993	12-BOR kit 12"	43
137994	15-BOR kit 15"	47
137995	18-BOR kit 18"	62
137996	24-BOR kit 24"	79
137990	P-21-RR Carbide Tooth (rock head)	0.6



## AGGRESSOR PARTS

	DIMENSIONS	WEIGHT
134519	40/50 Carbide Tooth (Aggressor)	0.4
134802	40/50 HFF Hardfaced tooth (Aggressor)	0.4
D001743	Nut & Bolt for Aggressor Tooth	0.2
135088	T350 Tri-Flow Pilot Bit	5
133407	Pilot Bit for 4" auger [SB-45]	3
134501	Standard 40/50 tooth for Aggressor auger	0.4



137990



135088



133407



134519



134802



134501



# INTERLOK AUGER BITS



The Interlok system of auger bits and couplers offers exceptional versatility – you can now connect to more drive sizes with one bit. Equipped with an innovative coupler system, Interlok Aggressor augers feature a heavy-duty twist lock collar on the bits. Drive side couplers are available in 2” and 2-9/16” round and 2” and 2 ½” hex sizes to fit the most common drive sizes.

## INTERLOK AUGERS

ITEM	NUMBER	WEIGHT
6” Aggressor Sub	157200	49
9” Aggressor Sub	157201	73
12” Aggressor Sub	157202	109
15” Aggressor Sub	157203	112
18” Aggressor Sub	157204	140
24” Aggressor Sub	157205	205
30” Aggressor Sub	157206	215
36” Aggressor Sub	157207	290



154015

## INTERLOK COUPLERS

ITEM	NUMBER	WEIGHT
R-200 INTERLOK (2” Round)	154073	5
R-256 INTERLOK (2-9/16” Round)	154074	5
H-200 INTERLOK (2” Hex)	154075	5
H-250 INTERLOK (2.5” Hex)	154076	5
Lock bolt	154015	1



2” HEX Drive



2 1/2” HEX Drive



2” Round Drive



2 9/16” Round Drive

Visit [baumalight.com](http://baumalight.com) for more information on available auger bits.

# CHEATER ADAPTERS



## 2" ROUND ADAPTERS

**D001286**  
2" Round FM to 2-9/16" Round Male Adapter - 15 lbs 

**D001287**  
2" Round FM to 2-9/16" Round Male Bushing - 2 lbs 

**D001319**  
2" Round FM to 2" Hex Male Adapter - 17 lbs 

## 2 9/16" ROUND ADAPTERS

**D001279**  
2-9/16" Round FM to 2" Round Male Adapter - 18 lbs 

**D001318**  
2-9/16" Round FM to 2" Hex Male Adapter - 17 lbs 

**D002997**  
2-9/16" FM to 2.5" Hex Male Adapter - 27 lbs 

## 2" HEX ADAPTERS

**D001280**  
2" Hex FM to 2" Round Male Adapter - 17 lbs 

**D001310**  
2" Hex FM to 2-9/16" Round Male Adapter - 17 lbs 

**D002996**  
2" Hex FM to 2.5" Hex Male Adapter - 23 lbs 

## 2.5" HEX ADAPTERS

**D002791**  
2.5" Hex FM to 2" Hex Male Adapter - 27 lbs 

**D002995**  
2.5" Hex FM to 2-9/16" Male Adapter - 32 lbs 

# BIT EXTENSIONS

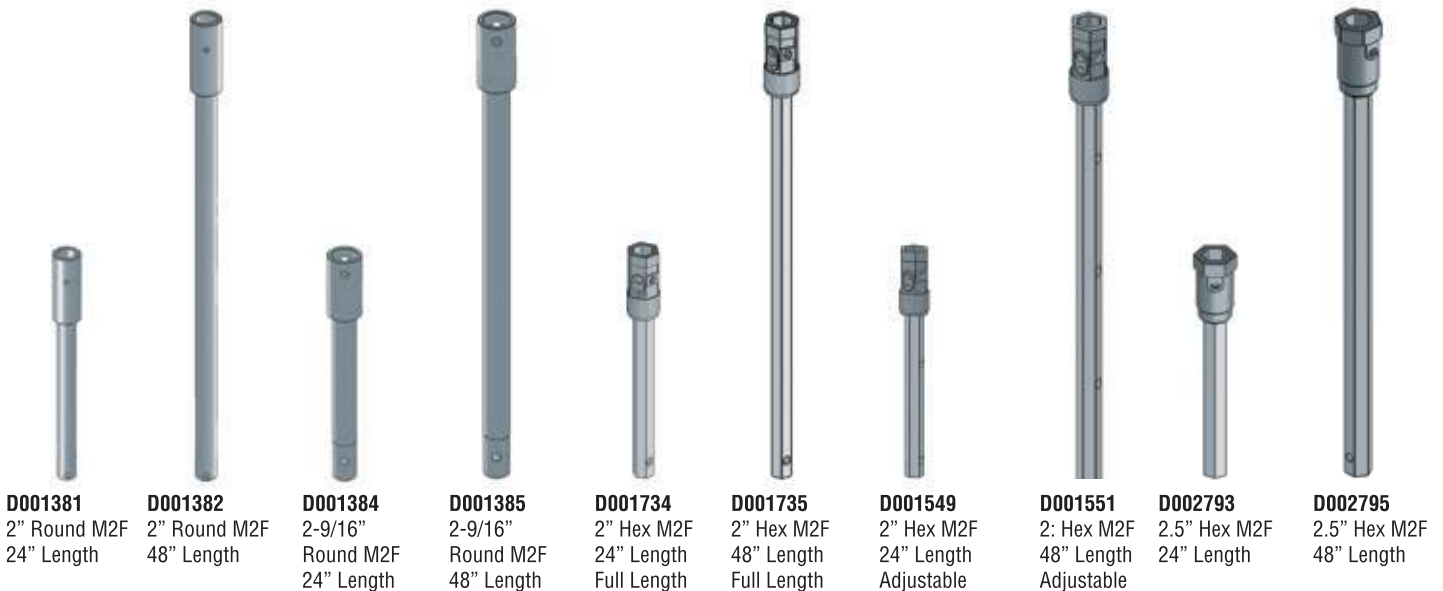

**D001381**  
2" Round M2F  
24" Length

**D001382**  
2" Round M2F  
48" Length

**D001384**  
2-9/16" Round M2F  
24" Length

**D001385**  
2-9/16" Round M2F  
48" Length

**D001734**  
2" Hex M2F  
24" Length  
Full Length

**D001735**  
2" Hex M2F  
48" Length  
Full Length

**D001549**  
2" Hex M2F  
24" Length  
Adjustable

**D001551**  
2: Hex M2F  
48" Length  
Adjustable

**D002793**  
2.5" Hex M2F  
24" Length

**D002795**  
2.5" Hex M2F  
48" Length

## FASTENER FOR 2" ROUND EXTENSIONS



**D001918**  
1/2 x 3.75 Bolt  
2" Round  
Auger Bit  
Extension



**D001919**  
1/2 Nylon  
Insert Locknut

## FASTENER FOR 2-9/16" ROUND EXTENSIONS



**D001920**  
7/8 x 5.5 Bolt  
2-9/16" Round  
Auger Bit  
Extension



**D001921**  
7/8 Nylon  
Insert Locknut

## PINS FOR 2" HEX EXTENSIONS



**D002008**  
3/4" Pin  
2" Hex Auger  
Bit Extension



**S1014**  
2" Hex  
Linch Pin

# MOUNTING PLATES

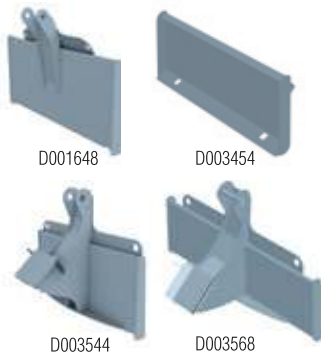

## BOBCAT MINI SKIDSTEER ASV RC30 & TERC PT30

PART #	PIN SIZE	CODE	DESCRIPTION	OPERATOR
D001648	1"	A & B	1" pin Bob Cat mini plate	Owner Operator
D003454	1"	A & B	1" pin ASV & Terex RC30 & PT30	Owner Operator
D003544	1.5"	D	1.5" pin Bobcat Mini Skidsteer	Construction
D003568	1.5"	D	1.5" pin ASV & Terex RC30 & PT30	Construction



## MINI SKIDSTEER

PART #	PIN SIZE	CODE	DESCRIPTION	OPERATOR
D001145	1"	A & B	1" pin Mini Skid steer plate	Owner Operator
D003532	1.5"	D	1.5" pin mini skidsteer plate / cradle	Construction
D004684	1"	B	1" pin mini skidsteer plate with cradle	Owner

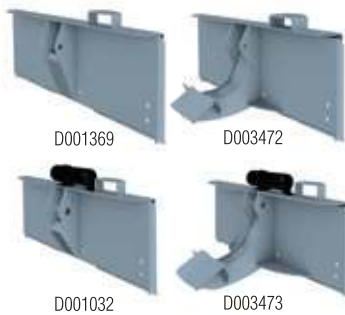

## UNIVERSAL MOUNT

PART #	PIN SIZE	CODE	DESCRIPTION	OPERATOR
D001369	1"	A & B	1" Pin Standard plate	Owner Operator
D003472	1"	B	1" Pin Standard plate with cradle	Owner Operator
D001032	1.5"	D	1.5" Pin Standard plate	Owner Operator
D003473	1.5"	D	1.5" Pin (Heavy) Plate with cradle	Construction



## WELD-ON PLATE

PART #	PIN SIZE	CODE	DESCRIPTION	OPERATOR
D001328	1"	A & B	Blank weld-on plate with shear pins	Owner
D003527	1"	B	1" pin blank weld on plate with cradle	Construction
D003528	1.5"	D	1.5" pin blank weld on plate / cradle	Construction
D001386	1.5"	D	Blank for weld-on plate	Owner



D001386



## HYDRAULIC HOSE KIT

PART #	DESCRIPTION	
D002118	Hose Set without couplers	4 ft
D002119	Hose Set without couplers	8 ft
D001698	Skid Steer Hose Set with Standard Flow Couplers (shown)	8 ft

Hoses not offered for excavator mount

Visit [baumalight.com](http://baumalight.com) for more mounting plate information and photos.

# TRENCHERS



## PRODUCT FEATURES

- Side auger keeps dirt clear when trenching
- Crumb scraper bar sweeps debris into the chain
- Planetary drive system
- Heavy duty solid steel nose
- Grease cylinder adjustable chain tensioner
- Wide variety of chain options & mounts
- Optional 3PH mount and external controls

Visit [baumalight.com](http://baumalight.com) for additional product information and product videos.

# MODELS



## TN236

**36" Trencher Depth**  
4" to 6" Trencher Width  
2-9/16" solid hardened steel main shaft  
Hydraulic relief over torque protection  
810 lbs.  
**Mini Skidsteer**  
20 GPM Max (7 GPM min)



## TN336

**36" Trencher Depth**  
4" to 6" Trencher Width  
2-9/16" solid hardened steel main shaft  
Hydraulic relief over torque protection  
Skidsteer up to 3 ton  
Quick Hitch Compatible: No  
850 lbs.  
**Skidsteer**  
20 GPM Max (10 GPM min)  
**Tractor**  
21 GPM Max (15 GPM min)



## TN548

**48" Trencher Depth**  
6" to 10" Trencher Width  
2-9/16" solid hardened steel main shaft  
Hydraulic relief over torque protection  
Skidsteer up to 4 ton  
Quick Hitch Compatible: No  
1,250 lbs.  
**Skidsteer**  
25 GPM Max (12 GPM min)  
**Tractor**  
25 GPM Max (18 GPM min)

## OPTIONS



## TN560

**60" Trencher Depth**  
6" to 10" Trencher Width  
2-9/16" solid hardened steel main shaft  
Hydraulic relief over torque protection  
Skidsteer from 3.5 ton  
Quick Hitch Compatible: No  
1,500 lbs.  
**Skidsteer**  
25 GPM Max (12 GPM min)  
**Tractor**  
25 GPM Max (22 GPM min)



## TN760

**60" Trencher Depth**  
6" to 10" Trencher Width  
Hex solid hardened steel main shaft  
Hydraulic relief over torque protection  
Skidsteer from 4 ton  
Quick Hitch Compatible: No  
1,800 lbs.  
**Skidsteer**  
42 GPM Max (20 GPM min)  
**Tractor**  
42 GPM Max (28 GPM min)



## 3PH TRACTOR MOUNT

This Baumalight Trencher can also be mounted to a tractor. The optional 3-point hitch tractor mount has a cylinder that provides angle and depth control. To use this 3PH adapter, your tractor must have a hydro-static drive and two hydraulic remotes. External control kit(S1050) is available for tractors with only one set of external hydraulic connections.  
Quick Hitch Compatible: No  
**D001393**

## 3PH EXTERNAL CONTROL

This optional external control kit is mounted on an adjustable arm. The control is great for smaller tractors with limited HP and for tractors with only one hydraulic remote.  
Quick Hitch Compatible: No  
**S1050**

## SPARE CHAIN

MODEL	DESCRIPTION	WEIGHT LBS
S3604	36X4" Standard cup tooth replacement chain	140
S3606	36X6" Standard cup tooth replacement chain	145
M3604	36x4" 50/50 rock & cup tooth replacement chain	150
M3606	36x6" 50/50 rock & cup tooth replacement chain	155
S4806	48X6" Standard cup tooth replacement chain	175
S4808	48X8" Standard cup tooth replacement chain	185
S4810	48X10" Standard cup tooth replacement chain	195
M4806	48X6" 50/50 rock & cup tooth replacement chain	209

MODEL	DESCRIPTION	WEIGHT LBS
M4808	48X8" 50/50 rock & cup tooth replacement chain	220
M4810	48X10" 50/50 rock & cup tooth replacement chain	230
S6006	60X6" Standard cup tooth replacement chain	192
S6008	60X8" Standard cup tooth replacement chain	203
S6010	60X10" Standard cup tooth replacement chain	214
M6006	60X6" 50/50 rock & cup tooth replacement chain	230
M6008	60X8" 50/50 rock & cup tooth replacement chain	242
M6010	60X10" 50/50 rock & cup tooth replacement chain	253

# TREE SPADES

## TRACTOR



### PRODUCT FEATURES

- Available with Electric control (see pictures online)
- Secure hydraulic connections and easy servicing
- All hoses are sleeved for operator and hose protection
- Heavy-duty construction and a durable powder-coated finish
- Lifting eyes for easy storage and transport
- Semi truncated blades
- Cylinders push for maximum efficiency
- Universal skidsteer adaptor if 3P is removed
- JIC fittings on hoses
- Power Built-in
- Greasable Pins
- Optional stabilizer
- Metal shipping stand (picture online)

Visit [baumalight.com](http://baumalight.com) for additional product information and product videos.

# TRACTOR MOUNT MODELS



## PT324

**20" Opening width**  
 2" Tree size (Evergreen)  
 1.5" Tree size (Hardwood)  
 24" Root ball diameter  
 23" Root ball depth  
 25° Blade angle  
 3 blades  
 1/4" Mild steel blades, Steel slides  
 Semi blade truncation  
 Quick Hitch Compatible: No  
 1,100 lbs unit weight  
 1,400 lbs weight with root ball  
**Minimum Carrier Weight**  
 3,000 lbs min



## PT330

**23" Opening width**  
 3" Tree size (Evergreen)  
 2.5" Tree size (Hardwood)  
 30" Root ball diameter  
 29" Root ball depth  
 25° Blade angle  
 3 blades  
 3/8" Mild steel blades, Steel slides  
 Semi blade truncation  
 Quick Hitch Compatible: No  
 1,356 lbs unit weight  
 1,865 lbs weight with root ball  
**Minimum Carrier Weight**  
 4,000 lbs min



## PS330

**60" Opening width**  
 3" Tree size (Evergreen)  
 2.5" Tree size (Hardwood)  
 30" Root ball diameter  
 29" Root ball depth  
 25° Blade angle  
 3 blades  
 3/8" Mild steel blades, Steel slides  
 Semi blade truncation  
 Towers Swing Hinge  
 Quick Hitch Compatible: No  
 1,550 lbs unit weight  
 2,050 lbs weight with root ball  
**Minimum Carrier Weight**  
 4,000 lbs min



## PT440

**52" Opening width**  
 4" Tree size (Evergreen)  
 3" Tree size (Hardwood)  
 40" Root ball diameter  
 30" Root ball depth  
 25° Blade angle  
 4 blades  
 1/4" High alloy AR400 blades, Steel slides  
 Full blade truncation  
 Towers Swing Hinge  
 Quick Hitch Compatible: No  
 1,934 lbs unit weight  
 3,134 lbs weight with root ball  
**Minimum Carrier Weight**  
 6,000 lbs min



## PT650

**47" Opening width**  
 3" Tree size (Evergreen)  
 2.5" Tree size (Hardwood)  
 30" Root ball diameter  
 29" Root ball depth  
 25° Blade angle  
 3 blades  
 1/4" High alloy AR400 blades, Steel slides  
 Semi blade truncation  
 Towers Swing Hinge  
 Quick Hitch Compatible: No  
 3,238 lbs unit weight  
 5,785 lbs weight with root ball  
**Minimum Carrier Weight**  
 10,000 lbs min

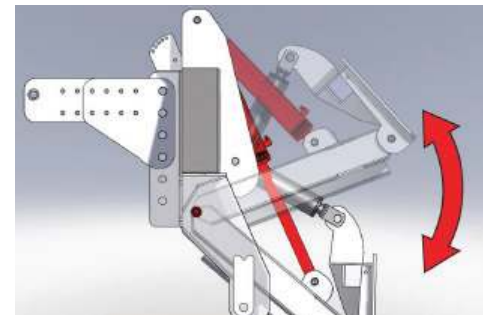

## Power Built-In

The 3-point hitch mount is designed for power and function. Attached to your tractor by a rigid top link and the lower arms in their lowest position, this rugged power house is ready to take on all the heavy lifting and positioning. The built-in hydraulics are designed to provide, tilt for positioning, down pressure to help keep the frame in position and lift to get the Nomad out of the hole. These powerful tools are also field installable, meaning you can add 3PH mount to an existing Nomad.

\*Comes with 20 ft of wire - Needs 12V wire to spade

# TREE SPADES

---

## SKIDSTEER



### PRODUCT FEATURES

- Non slip step pads for easy entry
- Available with Electric control (pictures online)
- All hoses are sleeved for operator and hose protection
- Heavy-duty construction and a durable powder-coated finish
- Lifting eyes for easy storage and transport
- Semi truncated blades
- Cylinders push for maximum efficiency
- Universal skidsteer adaptor
- Bolt in tractor loader adaptors available
- Optional stabilizer
- Optional Outrigger for skidsteers

Visit [baumalight.com](http://baumalight.com) for additional product information and product videos.



# SKIDSTEER MOUNT MODELS



## ST324

**20" Opening width**  
 2" Tree size (Evergreen)  
 1.5" Tree size (Hardwood)  
 24" Root ball diameter  
 23" Root ball depth  
 3 blades, 25° Blade angle  
 1/4" Mild steel blades, Steel slides  
 Semi blade truncation  
 1,100 lbs unit weight (1,400 lbs w/ root ball)



## ST330

**23" Opening width**  
 2" Tree size (Evergreen)  
 2.5" Tree size (Hardwood)  
 30" Root ball diameter  
 29" Root ball depth  
 3 blades, 25° Blade angle  
 3/8" Mild steel blades, Steel slides  
 Semi blade truncation  
 1,356 lbs unit weight (1,865 lbs w/ root ball)



## SS330

**60" Opening width**  
 3" Tree size (Evergreen)  
 2.5" Tree size (Hardwood)  
 30" Root ball diameter  
 29" Root ball depth  
 3 blades, 25° Blade angle  
 3/8" Mild steel blades, Steel slides  
 Semi blade truncation  
 Towers Swing Hinge  
 1,550 lbs unit weight (2,050 lbs w/ root ball)



## ST440

**52" Opening width**  
 4" Tree size (Evergreen)  
 3" Tree size (Hardwood)  
 40" Root ball diameter  
 30" Root ball depth  
 4 blades, 25° Blade angle  
 1/4" AR400 steel blades, Steel slides  
 Full blade truncation  
 Towers Swing Hinge  
 1,934 lbs unit weight (3,134 lbs w/ root ball)



## ST650

**47" Opening width**  
 5" Tree size (Evergreen)  
 4" Tree size (Hardwood)  
 50" Root ball diameter  
 43" Root ball depth  
 6 blades, 25° Blade angle  
 1/4" AR400 steel blades, Steel slides  
 Semi blade truncation  
 Towers Swing Hinge  
 3,238 lbs unit weight (5,785 lbs w/ root ball)

## CONTROL OPTIONS



Baumalight Tree Spades are available with multiple control options. Visit [www.baumalight.com](http://www.baumalight.com) for full details.

### Minimum Carrier Weight

MODEL	ST324	ST330	SS330	ST440	ST650
Wheeled Skidsteer	5,000 lbs	6,000 lbs	6,000 lbs	7,000 lbs	9,200 lbs
Tracked Skidsteer	4,500 lbs	5,200 lbs	5,200 lbs	6,500 lbs	8,500 lbs
Wheel Loader	4,000 lbs min	4,800 lbs min	4,800 lbs min	6,000 lbs min	8,000 lbs min
Tracked Loader	4,000 lbs min	5,200 lbs min	5,200 lbs min	7,800 lbs min	13,000 lbs min
Backhoe	4,000 lbs	4,800 lbs	4,800 lbs	6,000 lbs	8,000 lbs
Telehandler	4,000 lbs	4,800 lbs	4,800 lbs	6,000 lbs	8,000 lbs

\*Comes with 20 ft of wire - Needs 12V wire to spade

\*\*\*Extension plate required for some skidsteers, more information online

-Check online to see how many live pins are required

# TREE SPADES

 Holt industrial SKIDSTEER

## PRODUCT FEATURES

- Simple to use electronic over hydraulic control
- Dual cylinder design provides greater control
- Tower slides effortlessly with no binding and no greasing needed
- Two cylinders on each blade, this will allow you to disconnect one and keep planting should one fail
- Spades have a goose necked base allows the base to compress and keep the rootball intact while the blades dig in
- Frame is made from T1 material
- Full truncated blades
- Outside towers swing open
- Optional AUX Electrical Connection

Visit [baumalight.com](http://baumalight.com) for additional product information and product videos.



QUALITY BASKETS AT  
DOWN-TO-EARTH PRICES

[www.settler.biz](http://www.settler.biz)  
[sales@settler.biz](mailto:sales@settler.biz)  
call/text 519-589-1603



# SKIDSTEER MOUNT MODELS



## Holt industrial 34S

3.5" Tree size (Evergreen)  
3" Tree size (Hardwood)  
34" Root ball diameter  
23" Root ball depth  
4 blades, 25° Blade angle  
5/16 T1 blades, Nylon slides  
Full blade truncation  
5-25 gpm Hydraulic flow requirements  
2,000 min hydraulic psi  
1.47 Gallon Hydraulic Oil displacement  
1,650 lbs unit weight (2,100 lbs w/ root ball)  
Electric Controls\*



## Holt industrial 38S

4" Tree size (Evergreen)  
3.5" Tree size (Hardwood)  
38" Root ball diameter  
27" Root ball depth  
4 blades, 25° Blade angle  
5/16 T1 blades, Nylon slides  
Full blade truncation  
5-25 gpm Hydraulic flow requirements  
2,000 min hydraulic psi  
1.71 Gallon Hydraulic Oil displacement  
1,920 lbs unit weight (2,720 lbs w/ root ball)  
Electric Controls\*



## Holt industrial 44S

4.5" Tree size (Evergreen)  
4" Tree size (Hardwood)  
44" Root ball diameter  
31" Root ball depth  
4 blades, 25° Blade angle  
5/16 T1 blades, Nylon slides  
Full blade truncation  
5-25 gpm Hydraulic flow requirements  
2,000 min hydraulic psi  
1.96 Gallon Hydraulic Oil displacement  
2,210 lbs unit weight (3,410 lbs w/ root ball)  
Electric Controls\*



## Holt industrial 48S

5" Tree size (Evergreen)  
4.5" Tree size (Hardwood)  
48" Root ball diameter  
38" Root ball depth  
4 blades, 25° Blade angle  
5/16 T1 blades, Nylon slides  
Full blade truncation  
5-25 gpm Hydraulic flow requirements  
2,000 min hydraulic psi  
1.96 Gallon Hydraulic Oil displacement  
2,740 lbs weight (5,240 lbs w/ root ball)  
Electric Controls\*



## Holt industrial 50S

5.5" Tree size (Evergreen)  
5" Tree size (Hardwood)  
50" Root ball diameter  
44" Root ball depth  
4 blades, 25° Blade angle  
5/16 T1 blades, Nylon slides  
Semi blade truncation  
5-25 gpm Hydraulic flow requirements  
2,000 min hydraulic psi  
2.94 Gallon Hydraulic Oil displacement  
3,220 lbs weight (5,705 lbs w/ root ball)  
Electric Controls\*



### Minimum Carrier Weight

MODEL	34S	38S	44S	48S	50S
Wheeled Skidsteer	6,200 lbs	7,000 lbs	8,800 lbs	10,000 lbs	10,500 lbs
Tracked Skidsteer	5,900 lbs	6,500 lbs	8,300 lbs	9,500 lbs	10,000 lbs
Wheel Loader	5,400 lbs min	6,000 lbs min	7,500 lbs min	8,500 lbs min	9,000 lbs min
Tracked Loader	7,000 lbs min	7,800 lbs min	10,400 lbs min	12,500 lbs min	13,000 lbs min
Backhoe	5,400 lbs	6,000 lbs	7,500 lbs	8,500 lbs	9,000 lbs
Telehandler	5,400 lbs	6,000 lbs	7,500 lbs	8,500 lbs	9,000 lbs

\*Comes with 20 ft of wire - Needs 12V wire to spade

# TREE SCOOPS



## PRODUCT FEATURES

- Safety grip step strips on the top make getting in and out of your skid steer safe and easier
- The mounting plate/adaptor/tool carrier is double reinforced at both the top and the bottom.
- gusseted for additional strength
- 8 panel structured shape gives the scoop added strength
- Sharp blade truncation

Visit [baumalight.com](http://baumalight.com) for additional product information and product videos.

## TREE SCOOP MODELS



### X4M

**23" Scoop width**  
 24" Plate width  
 1.5" Tree size (Evergreen)  
 1" Tree size (Hardwood)  
 22" Root ball diameter  
 20" Root ball depth  
 1/4" High Alloy AR400 blade  
 Standard Mini Skid Steer attachment  
 35" Length



### X4C

**23" Scoop width**  
 36" Plate width  
 1.5" Tree size (Evergreen)  
 1" Tree size (Hardwood)  
 22" Root ball diameter  
 20" Root ball depth  
 1/4" High Alloy AR400 blade  
 Bobcat Mini Skid Steer attachment  
 36" Length



### X4S

**28" Scoop width**  
 44" Plate width  
 2" Tree size (Evergreen)  
 1.5" Tree size (Hardwood)  
 28" Root ball diameter  
 25" Root ball depth  
 1/4" High Alloy AR400 blade  
 Standard Universal Skid Steer attachment  
 Bolt-on loader adapter available  
 43" Length  
**Minimum Carrier Weight**  
 Wheeled Skidsteer 4,400 lbs  
 Tracked Skidsteer 4,000 lbs  
 Wheel Loader 3,500 lbs min  
 Backhoe 3,500 lbs  
 Telehandler 3,500 lbs



### X4B

**28" Scoop width**  
 44" Plate width  
 2" Tree size (Evergreen)  
 1.5" Tree size (Hardwood)  
 28" Root ball diameter  
 25" Root ball depth  
 1/4" High Alloy AR400 blade  
 Blank Weld-On Skid Steer attachment  
 43" Length  
**Minimum Carrier Weight**  
 Wheeled Skidsteer 4,400 lbs  
 Tracked Skidsteer 4,000 lbs  
 Wheel Loader 3,500 lbs Min.  
 Backhoe 3,500 lbs  
 Telehandler 3,500 lbs

# TREE SPADES TRAILER



## PRODUCT FEATURES

- Hydraulic Tongue
- Hydraulic lateral placement
- 2 stage vertical placement
- Gas powered
- Intergrated Safety Chain
- Standard Pintle Hitch
- Hardened Steel Bushing
- Greasable pins
- 20 HP Honda GX630 - 688cc Engine

Visit [baumalight.com](http://baumalight.com) for additional product information and product videos.

## TRAILER MOUNT MODELS



**BAUMALIGHT**

**BAUMALIGHT**

**BAUMALIGHT**

**Holt industrial**

### TR330

**60" Opening width**  
3" Tree size (Evergreen)  
2.5" Tree size (Hardwood)  
30" Root ball diameter  
29" Root ball depth  
3 25° Blade angle  
3/8" Mild steel blades, Steel slides  
Semi blade truncation  
Towers Swing Hinge  
Quick Hitch Compatible: No  
3,950 lbs unit weight  
4450 lbs weight with root ball

### TR440

**52" Opening width**  
4" Tree size (Evergreen)  
3" Tree size (Hardwood)  
40" Root ball diameter  
30" Root ball depth  
4 25° angle blades  
1/4" AR400 steel blades  
Full blade truncation  
Towers Swing Hinge  
Quick Hitch Compatible: No  
4,150 lbs unit weight  
4,986 lbs weight with root ball

### TR650

**47" Opening width**  
5" Tree size (Evergreen)  
4" Tree size (Hardwood)  
50" Root ball diameter  
43" Root ball depth  
6 25° angle blades  
1/4" AR400 steel blades  
Semi blade truncation  
Towers Swing Hinge  
Quick Hitch Compatible: No  
8,238 lbs unit weight  
10,785 lbs weight with root ball

### M33-HOLT50S

**61/2'\*12' Size**  
5.5" Tree size (Evergreen)  
4" Tree size (Hardwood)  
50" Root ball diameter  
44" Root ball depth  
4 25° angle blades  
5/16" T1 blades, nylon slides  
Semi blade truncation  
Quick Hitch Compatible: No  
7,250 lbs unit weight  
9,735 lbs weight with root ball

# GENERATORS

## TX SERIES

**8 WEEKS**  
**SAVES \$8%**

PRE-ORDER DISCOUNT



GENERATOR ASSEMBLY MADE IN CANADA  
MAIN COMPONENT IS MADE IN EUROPE

### PRODUCT FEATURES

- Easy view voltage meter
- Brushless design and copper windings
- Push button circuit breaker reset
- Internal operating speed of 3,600 rpm
- Multiple connections on panel
- Self-regulated power within +/- 6%
- 2 year/2000 hour limited warranty

Visit [baumalight.com](http://baumalight.com) for additional product information and product videos.

# TX GENERATOR MODELS



## TX MODEL SPECIFICATIONS

MODEL	MAX ELECTRIC MOTOR SIZE CONNECTION	KW	MOMENTARY SURGE KW	MIN TRACTOR 50% LOAD	100% LOAD	120V 20 AMP DUPLEX	WELDER RECEPT VOLTAGE	VOLTS	FULL OUTPUT AMPS	PHASE	SHIP WEIGHT (LBS)
TX 7	Dedicated	7	14	5HP	11HP	1	240	120/240	30	1	300
TX 12	Dedicated	12	24	10HP	21HP	2	240	120/240	50	1	370
TX 18	Dedicated	18	37	15HP	34HP	2	240	120/240	80	1	474
TX 25	Dedicated	25	50	19HP	42HP	2	240	120/240	100	1	563
TX 31	Dedicated	31	62	22HP	50HP	2	240	120/240	125	1	596

SEE GENERATOR SIZE CALCULATOR ONLINE

**8 WEEKS 8%  
\$ SAVES \$ 8**

### PLANNING AHEAD PAYS OFF. PRE-ORDER DISCOUNT PROGRAM.

To reward and encourage you to plan ahead, BaumaLight is offering an 8% discount on pre-ordered generators. This program allows you to order a generator at a discount for delivery in 8 weeks. We all know being prepared before an emergency is best but we all get caught off guard once in a while. This program allows us to reward the prepared and also keep stock for the times when customers have immediate needs.

# GENERATORS

## KR SERIES

**8 WEEKS**  
**SAVES \$8%**

PRE-ORDER DISCOUNT



**GENERATOR ASSEMBLY MADE IN CANADA  
MAIN COMPONENT IS MADE IN EUROPE**

### PRODUCT FEATURES

- Comes with DisplayMaster1 monitoring system
- Reset circuit breakers - protect against short circuit damage
- Brushless design means improved performance with less maintenance
- 4 Copper windings provide more efficient power generation
- Oversized windings enhance quality and stability of power
- Neutral bonded to ground
- Internal operating speed of 1,800 RPM
- Lower Operating Speed increases duty cycle and operating life
- Speed indicating lights make set up quick and easy
- Automatic voltage regulation keeps power stable within 1% +/- down to 56Hz
- High momentary surge capacity up to 3 times working wattage rating for excellent motor starting
- Multiple connection options including:
  - Full power outlet with locking cover
  - 20 amp duplex receptacle
  - 50 amp welder receptacle
- Drip Proof design
- Limited 2 Year/2000 hour Warranty

Visit [baumalight.com](http://baumalight.com) for additional product information and product videos.



# KR GENERATOR MODELS



## KR MODEL SPECIFICATIONS

MODEL	CONNECTION	KW	MOMENTARY SURGE KW	MIN TRACTOR 50% LOAD	100% LOAD	120V 20 AMP DUPLEX	WELDER RECEPT VOLTAGE	VOLTS	FULL OUTPUT AMPS	PHASE	SHIP WEIGHT (LBS)
KR30	Dedicated	30	85	23	45	2	240	120/240	125	1	750
KR44	Dedicated	44	115	34	65	2	240	120/240	175	1	990
KR52	Dedicated	52	140	39	76	2	240	120/240	225	1	1,060
KR65	Dedicated	65	180	52	97	2	240	120/240	250	1	1,210

SEE GENERATOR SIZE CALCULATOR ONLINE

# DisplayMaster1

## AT A GLANCE PERFORMANCE MONITOR

- Voltage, Frequency & Amperage
- KW, KVA, Power Factor
- Runtime & KW Hours
- Peak/Average KVA
- Speed indicating lights

WATCH ONLINE VIDEO FOR MORE INFORMATION



Included on all KR & QC Models

# GENERATORS

## QC SERIES

**8 WEEKS**  
**SAVES \$8%**

PRE-ORDER DISCOUNT

*DisplayMaster1*



**GENERATOR ASSEMBLY MADE IN CANADA  
MAIN COMPONENT IS MADE IN AMERICA**

### PRODUCT FEATURES

- Comes with DisplayMaster1 monitoring system
- Reset circuit breakers - protect against short circuit damage
- Brushless design means improved performance with less maintenance
- 4 Copper windings provide more efficient power generation
- Oversized windings enhance quality and stability of power
- Neutral bonded to ground
- Internal operating speed of 1,800 RPM
- Lower Operating Speed increases duty cycle and operating life
- Speed indicating lights make set up quick and easy
- Automatic voltage regulation keeps power stable within 1% +/- down to 56Hz
- High momentary surge capacity up to 3 times working wattage rating for excellent motor starting
- Multiple connection options including:
  - Full power outlet with locking cover
  - 20 amp duplex receptacle
  - 50 amp welder receptacle
- Drip Proof design
- Limited 2 Year/2000 hour Warranty

Visit [baumalight.com](http://baumalight.com) for additional product information and product videos.

# QC GENERATOR MODELS



## QC MODEL SPECIFICATIONS

MODEL	CONNECTION	KW	MOMENTARY SURGE KW	MIN TRACTOR		RPM	WELDER RECEPT VOLTAGE	VOLTS	FULL OUTPUT AMPS	PHASE	SHIP WEIGHT (LBS)
				50% LOAD	100% LOAD						
QC12	Dedicated	12	25	9HP	21HP	540	240	120/240	50	1	645
QC19	Dedicated	19	35	16HP	34HP	540	240	120/240	90	1	685
QC30	Dedicated	30	85	20HP	49HP	540	240	120/240	125	1	725
QC45	Dedicated	45	120	31HP	75HP	540	240	120/240	175	1	941
QC55	Dedicated	55	150	42HP	89HP	540	240	120/240	225	1	1037
QC65	Dedicated	65	180	48HP	102HP	540	240	120/240	250	1	1156
QC80	Dedicated	80	225	55HP	122HP	1000	240	120/240	320	1	1358
QC100	Dedicated	100	300	71HP	153HP	1000	240	120/240	400	1	1450
<b>SEE GENERATOR SIZE CALCULATOR ONLINE</b>											
QC30-2	Parallel Low WYE	30	85	20HP	49HP	540	208	120/208	100	3	779
QC45-2	Parallel Low WYE	45	120	31HP	75HP	540	208	120/208	150	3	980
QC68-2	Parallel Low WYE	68	190	50HP	105HP	540	208	120/208	250	3	1160
QC105-2	Parallel Low WYE	105	315	72HP	155HP	1000	208	120/208	400	3	1474
QC30-3	Series High DELTA	30	85	20HP	49HP	540	240	120/240	90	3	779
QC45-3	Series High DELTA	45	120	31HP	75HP	540	240	120/240	150	3	995
QC68-3	Series High DELTA	68	190	50HP	105HP	540	240	120/240	225	3	1160
QC105-3	Series High DELTA	105	315	72HP	155HP	1000	240	120/240	320	3	1474
QC30-4	Series High WYE	33	99	20HP	49HP	540	n/a	277/480	50	3	779
QC45-4	Series High WYE	50	150	31HP	75HP	540	n/a	277/480	80	3	995
QC68-4	Series High WYE	76	228	50HP	105HP	540	n/a	277/480	125	3	1160
QC105-4	Series High WYE	113	339	72HP	155HP	1000	n/a	277/480	150	3	1474
QC27-6	Dedicated	27	45	18HP	47HP	540	n/a	347/600	35	3	779
QC50-6	Dedicated	50	130	35HP	80HP	540	n/a	347/600	60	3	1010
QC75-6	Dedicated	75	200	52HP	110HP	1000	n/a	347/600	90	3	1175
QC100-6	Dedicated	100	100	71HP	153HP	1000	n/a	347/600	150	3	1475

# STUMP GRINDERS TRACTOR

**FREE**  
6 Pack of REPLACEMENT  
TEETH  
WITH PURCHASE  
SEE ONLINE FOR DETAILS



## PRODUCT FEATURES

- Adjustable flow control for optimal performance
- High number of carbide tipped cutting teeth
- Rugged gear boxes rated from 803 to 1050 ft.-lbs of torque
- 3/4" thick steel rotor
- Floating deflector shield
- Stabilizer base for consistent grinding

Visit [baumalight.com](http://baumalight.com) for additional product information and product videos.

# TRACTOR MOUNT MODELS



## 1P24

20-45 Recommended HP  
50 Maximum Engine HP  
40 Maximum PTO HP  
24" Rotor Size  
540 RPM Cutting Wheel Speed  
10" Cutting Height - Above Ground  
6" Cutting Depth - Below Ground  
5" Maximum Cutting Depth - Per Pass  
22" Maximum Horizontal Cut  
0° Swing Arc  
803 Ft.-Lbs. Hub Torque  
Shear bolt Over Torque Protection  
Cat I Hitch  
Quick Hitch Compatible: Yes  
Slip Clutch PTO Shaft  
Remote not required  
12 Volt DC Not Required  
540 Input Speed  
350 Lbs Unit Weight (Shipping)  
48" Width (Shipping)  
48" Length (Shipping)  
Replacement Teeth: S1000 Teeth\*  
34 Teeth



## 3P24

25-55 Recommended HP  
65 Maximum Engine HP  
55 Maximum PTO HP  
5-20 Hydraulic GPM  
24" Rotor Size  
810 RPM Cutting Wheel Speed  
18" Cutting Height - Above Ground  
8" Cutting Depth - Below Ground  
6" Maximum Cutting Depth - Per Pass  
22" Maximum Horizontal Cut  
65° Swing Arc  
803 Ft.-Lbs. Hub Torque  
Slip Clutch Over Torque Protection  
Cat I or II Hitch  
Quick Hitch Compatible: No  
2 Remotes Required - Hydraulic\*\*  
12 Volt DC Not Required  
540 Input Speed  
624 Lbs Unit Weight (Shipping)  
42" Width (Shipping)  
49" Length (Shipping)  
Replacement Teeth: S1000 Teeth\*  
34 Teeth



## 3P34

45-80 Recommended HP  
85 Maximum Engine HP  
75 Maximum PTO HP  
5-20 Hydraulic GPM  
34" Rotor Size  
810 RPM Cutting Wheel Speed  
25" Cutting Height - Above Ground  
14" Cutting Depth - Below Ground  
9" Maximum Cutting Depth - Per Pass  
32" Maximum Horizontal Cut  
65° Swing Arc  
803 Ft.-Lbs. Hub Torque  
Slip Clutch Over Torque Protection  
Cat II Hitch  
Quick Hitch Compatible: No  
2 Remotes Required - Hydraulic\*\*  
12 Volt DC Not Required  
540 Input Speed  
1231 Lbs Unit Weight (Shipping)  
48" Width (Shipping)  
54" Length (Shipping)  
Replacement Teeth: S1000 Teeth\*  
54 Teeth



## 3P40

60-120 Recommended HP  
125 Maximum Engine HP  
115 Maximum PTO HP  
5-20 Hydraulic GPM  
34" Rotor Size  
1000 RPM Cutting Wheel Speed  
25" Cutting Height - Above Ground  
14" Cutting Depth - Below Ground  
9" Maximum Cutting Depth - Per Pass  
32" Maximum Horizontal Cut  
65° Swing Arc  
1050 Ft.-Lbs. Hub Torque  
Slip Clutch Over Torque Protection  
Cat II Hitch  
Quick Hitch Compatible: No  
2 Remotes Required - Hydraulic\*\*  
12 Volt DC Not Required  
1,000 Input Speed  
1280 Lbs Unit Weight (Shipping)  
48" Width (Shipping)  
54" Length (Shipping)  
Replacement Teeth: S1000 Teeth\*  
54 Teeth

Tractor must have hydro-static drive  
On subcompact tractors with short arms, the D005735 Extension Kit is required

\*\*S1050 External Control required if only 1 remote available



### D005735 EXTENSION KIT

Before using the 1P24 you must first measure your tractor to see if you require the D005735 Extension Kit.

Learn more at [baumalight.com](http://baumalight.com)

### S1050 EXTERNAL TRACTOR CONTROL

This optional control is mounted on an adjustable arm. The control is great for smaller tractors with limited HP for better cutting control and for tractors with only one remote.

Learn more at [baumalight.com](http://baumalight.com)



## TRACTOR STUMP CUTTING TIMES BASED ON 30" STUMP

MODEL	20 HP	30 HP	40 HP	60 HP	70 HP	80 HP	90 HP	120 HP
1P24	30 min	20 min	15 min	--	--	--	--	--
3P24	--	15 min	12 min	10 min	--	--	--	--
3P34	--	--	--	6 min	5 min	4 min	--	--
3P40	--	--	--	6 min	5 min	4 min	3 min	2 min

# STUMP GRINDERS

---

## SKIDSTEER

**FREE**  
6 Pack of REPLACEMENT  
Teeth  
WITH PURCHASE  
SEE ONLINE FOR DETAILS



### PRODUCT FEATURES

- Adjustable flow control for optimal performance
- High number of carbide tipped cutting teeth
- AUX electrical connection available for in cab controls
- Double shielded hoses
- Floating deflector shield
- 12V remote control if no AUX plug

Visit [baumalight.com](http://baumalight.com) for additional product information and product videos.

# SKIDSTEER MOUNT MODELS



## S16

Mini Skidsteer model with swing cylinder  
Check GPM & PSI for Maximum Carrier Size

Gear Motor  
Check Stump Cutting Size Chart for Hydraulic GPM

Cutting Wheel Speed Depends on GPM  
No limit Cutting Height - Above Ground

Relieve valve Over Torque Protection  
Mini Plate Hitch  
1 Remote Required - Hydraulic  
Requires 12 Volt DC

Replacement Teeth: H3000 high speed teeth

Includes adapter.  
Hoses and couplers included

## S24

30-80 Recommended HP size  
Check GPM & PSI for Maximum Carrier Size

Roller Vane Motor  
Check Stump Cutting Size Chart for Hydraulic GPM  
24" Rotor Size

Cutting Wheel Speed Depends on GPM  
No limit Cutting Height - Above Ground  
10" Cutting Depth - Below Ground  
6" Maximum Cutting Depth - Per Pass  
22" Maximum Horizontal Cut

80° Swing Arc  
250 Ft.-Lbs. Hub Torque  
Relieve valve Over Torque Protection  
Quick Attach Hitch

1 Remote Required - Hydraulic  
Requires 12 Volt DC  
920 Lbs Unit Weight (Shipping)  
Replacement Teeth: S1000\*  
34 Teeth

Includes adapter.  
Hoses included, couplers NOT included.  
Deduct \$100 if ordered with AUX.

## S28

50-120 Recommended HP size  
Check GPM & PSI for Maximum Carrier Size

Roller Vane Motor  
Check Stump Cutting Size Chart for Hydraulic GPM  
24" Rotor Size

Cutting Wheel Speed Depends on GPM  
No limit Cutting Height - Above Ground  
10" Cutting Depth - Below Ground  
6" Maximum Cutting Depth - Per Pass  
22" Maximum Horizontal Cut

80° Swing Arc  
803 Ft.-Lbs. Hub Torque  
Relieve valve Over Torque Protection  
Quick Attach Hitch

1 Remote Required - Hydraulic  
Requires 12 Volt DC  
995 Lbs Unit Weight (Shipping)  
Replacement Teeth: S1000\*  
34 Teeth

Includes adapter.  
Hoses included, couplers NOT included.  
Deduct \$100 if ordered with AUX.

## S40

50-130 Recommended HP size  
Check GPM & PSI for Maximum Carrier Size

High Efficiency Bent Axis Piston  
Check Stump Cutting Size Chart for Hydraulic GPM

24" Rotor Size  
Cutting Wheel Speed Depends on GPM  
No limit Cutting Height - Above Ground  
24" Cutting Depth - Below Ground  
2" Maximum Cutting Depth - Per Pass  
22" Maximum Horizontal Cut

85° Swing Arc (cuts both ways)  
Relieve valve Over Torque Protection  
Quick Attach Hitch

1 Remote Required - Hydraulic  
Requires 12 Volt DC  
1,200 Lbs Unit Weight (Shipping)  
Replacement Teeth: H3000 high speed teeth  
20 Teeth

Includes adapter.  
Hoses included, couplers NOT included.  
Deduct \$100 if ordered with AUX.

### Optional Hand-Held Controls

D004460 - Available Stump Grinder wired hand-held control that connects to male AUX with a 4 ft wire



## SKIDSTEER STUMP CUTTING TIMES BASED ON 24" STUMP

MOTOR	CASE DRAIN	PSI	12 GPM	15 GPM	20 GPM	25 GPM	30 GPM	35 GPM	40 GPM	50 GPM	CC	MOTOR TYPE	RPM AT MAX GPM
S400 Motor Available for: S16	Required	2,500	50 min	40 min	--	--	--	--	--	--	25	Gear	2300
		3,000	40 min	35 min	--	--	--	--	--	--			
S445 Motor Available for: S24	Recommended	2,500	--	60 min	40 min	35 min	--	--	--	--	125	Roller Vane	520
		3,000	--	50 min	30 Min	30 Min	--	--	--	--			
S545 Motor Available for: S24	Recommended	2,500	--	--	40 min	35 min	25 min	20 min	--	--	130	Roller Vane	700
		3,000	--	--	30 Min	30 Min	20 Min	16 Min	--	--			
S645 Motor Available for: S28	Recommended	2,500	--	--	--	40 min	25 Min	15 Min	12 Min	10 Min	130	Roller Vane	540
		3,000	--	--	--	40 min	25 Min	15 Min	12 Min	10 Min			
S740 Motor Available for: S40	Required	2,500	--	--	30 min	15 min	12 min	10 min	--	--	56	Piston	2100
		3,000	--	--	25 min	12 min	10 min	8 min	--	--			
S770 Motor Available for: S40	Required	2,500	--	--	--	30 min	12 min	10 min	8 min	7 min	84	Piston	2000
		3,000	--	--	--	25 min	10 min	8 min	7 min	6 min			

\*Motors will run at this PSI, but excess pressure is dumping over relief.  
5 GPM is used for swing cylinder.

# STUMP GRINDERS DEDICATED EXCAVATOR

**FREE**  
6 Pack <sup>of REPLACEMENT</sup>  
TEETH  
WITH PURCHASE  
SEE ONLINE FOR DETAILS

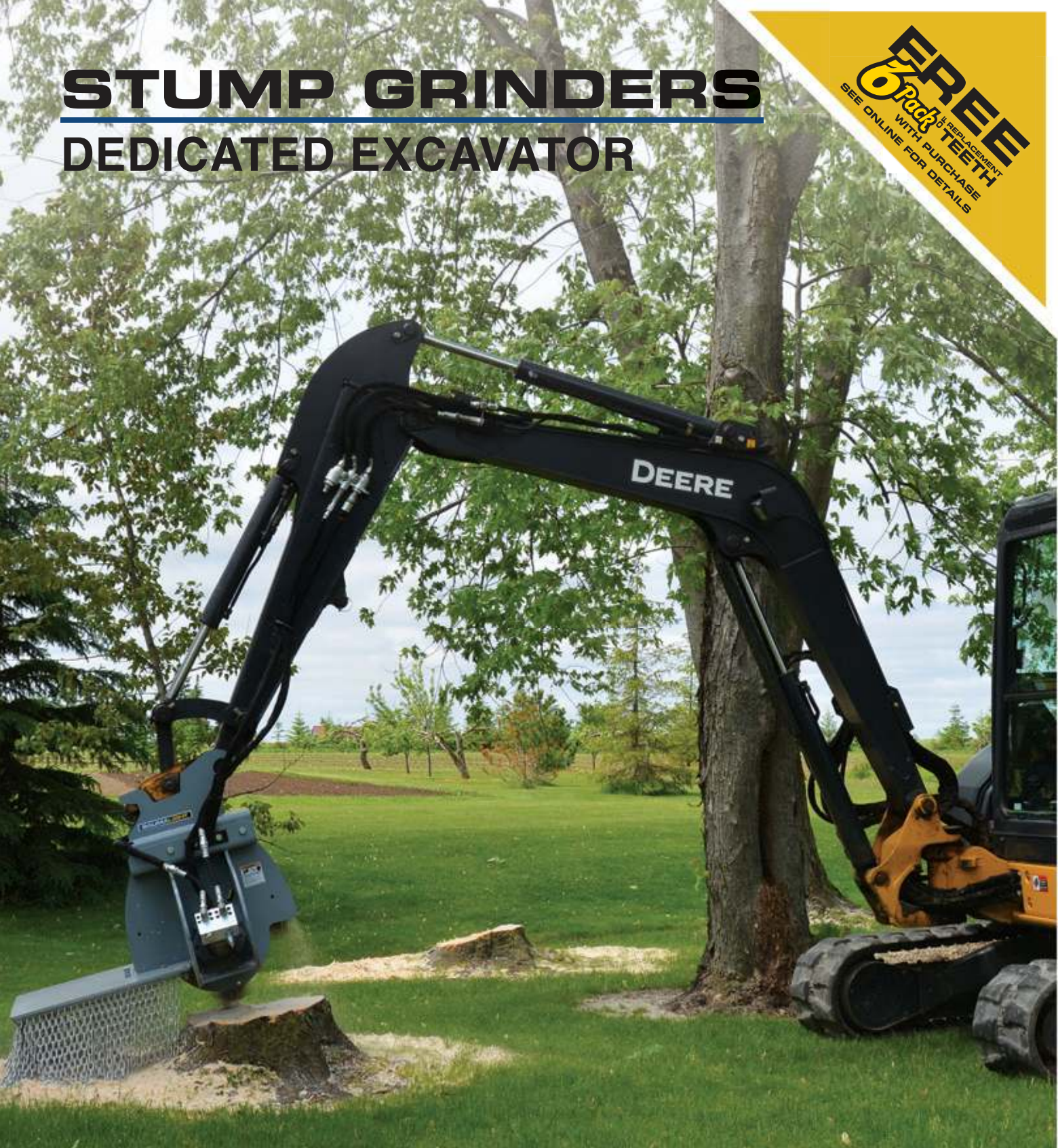

## PRODUCT FEATURES

- Concave shaped carbide tipped green teeth
- High number of teeth means they last longer
- Bent axis piston motor
- More tooth clearance for better performance
- Chain curtain blast shield
- Heavy duty steel rotor

Visit [baumalight.com](http://baumalight.com) for additional product information and product videos.



# EXCAVATOR MOUNT MODELS

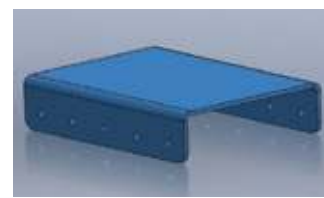

## GXM350

1.5-4.5 ton Recommended Carrier Size  
High Efficiency Bent Axis Piston Motor  
Check motor options for Hydraulic GPM  
19" Rotor Size  
Cutting Wheel Speed Depends on GPM  
No limit Cutting Height - Above Ground  
16" Cutting Depth - Below Ground  
3/4" Maximum Cutting Depth - Per Pass  
12" Maximum Horizontal Cut  
Relieve valve Over Torque Protection  
Bolt on adapter  
1 remote required - hydraulic  
12 Volt DC not required  
650 Lbs (shipping)  
Replacement Teeth: H3000 high speed teeth  
16 Teeth

Adapter sold separately.  
Hoses and couplers NOT included.

## GXM550

3.5 - 8 ton Recommended Carrier Size  
High Efficiency Bent Axis Piston Motor  
Check motor options for Hydraulic GPM  
24" Rotor Size  
Cutting Wheel Speed Depends on GPM  
No limit Cutting Height - Above Ground  
24" Cutting Depth - Below Ground  
1" Maximum Cutting Depth - Per Pass  
22" Maximum Horizontal Cut  
Relieve valve Over Torque Protection  
Bolt on adapter  
1 remote required - hydraulic  
12 Volt DC not required  
822 Lbs (shipping)  
Replacement Teeth: H3000 high speed teeth  
20 Teeth

Adapter sold separately.  
Hoses and couplers NOT included.

## GXM750

7 - 18 ton Recommended Carrier Size  
High Efficiency Bent Axis Piston Motor  
Check motor options for Hydraulic GPM  
24" Rotor Size  
Cutting Wheel Speed Depends on GPM  
No limit Cutting Height - Above Ground  
24" Cutting Depth - Below Ground  
1" Maximum Cutting Depth - Per Pass  
22" Maximum Horizontal Cut  
Relieve valve Over Torque Protection  
Bolt on adapter  
1 remote required - hydraulic  
12 Volt DC not required  
1300 Lbs (shipping)  
Replacement Teeth: H3000 high speed teeth  
20 Teeth

Adapter sold separately.  
Hoses and couplers NOT included.

## EXCAVATOR ADAPTER

**D001161**  
Blank Weld-on Plate  
Bolt on Connection  
48 lbs  
See the back of the catalog for pricing and our turn-key mounting options.



## EXCAVATOR STUMP CUTTING TIMES BASED ON 24" STUMP

MOTOR	CASE DRAIN	PSI	12 GPM	15 GPM	20 GPM	25 GPM	30 GPM	35 GPM	40 GPM	50 GPM	60 GPM	CC	MOTOR TYPE	RPM AT MAX GPM
X508 Motor Available for: GXM350, GXM550	Critical	3,000	25 min	20 min	--	--	--	--	--	--	--	25	Piston	2300
		4,000	20 min	15 min	--	--	--	--	--	--	--			
X510 Motor Available for: GXM350, GXM550	Critical	3,000	25 min	15 min	8 min	7 min	--	--	--	--	--	34	Piston	4290
		4,000	20 min	10 min	7 Min	5 Min	--	--	--	--	--			
X530 Motor Available for: GXM350, GXM550	Critical	3,000	--	16 min	8 min	7 min	7 min	--	--	--	--	47	Piston	2100
		4,000	--	11 min	7 Min	5 Min	5 min	--	--	--	--			
X540 Motor Available for: GXM550, GXM750	Critical	3,000	--	--	8 min	7 min	6 min	5 min	--	--	--	65	Piston	2100
		4,000	--	--	7 min	5 min	5 min	4 min	--	--	--			
X550 Motor Available for: GXM550, GXM750	Critical	3,000	--	--	--	7 min	6 min	5 min	4 min	--	--	64	Piston	2140
		4,000	--	--	--	5 min	5 min	4 min	3 min	--	--			
X570 Motor Available for: GXM750	Critical	3,000	--	--	--	--	7 min	6 min	4 min	3 min	--	84	Piston	2000
		4,000	--	--	--	--	6 min	4 min	3 min	3 min	--			
X590 Motor Available for: GXM750	Critical	3,000	--	--	--	--	--	--	5 min	3 min	3 min	108	Piston	1900
		4,000	--	--	--	--	--	--	3 min	3 min	2 min			

# STUMP GRINDERS

## MULTI CARRIER

**FREE**  
6 Pack  
OF REPLACEMENT  
WITH PURCHASE  
TEETH  
SEE ONLINE FOR DETAILS



### PRODUCT FEATURES

- Mounted on either Skidsteer or Excavator
- High number of teeth means they last longer
- All available hydraulic power goes to Hydraulic Motor
- Very few moving parts
- Simple design for simple maintenance

Visit [baumalight.com](http://baumalight.com) for additional product information and product videos.

# MULTI CARRIER MOUNT MODELS



## S14

### Skidsteer Mount Specs:

12-30 Recommended HP  
Check GPM & PSI for Max. Carrier Size  
Check Stump Cutting Size Chart for Hydraulic GPM

### Excavator Mount Specs:

1-2 Ton Recommended Carrier Size  
Check Motor Options for Hydraulic GPM

Gerotor Motor  
18" Rotor Size  
Cutting Wheel Speed Depends on GPM  
No limit Cutting Height - Above Ground  
6" Cutting Depth - Below Ground  
2" Maximum Cutting Depth - Per Pass  
12" Maximum Horizontal Cut  
Self-feeding Swing Arc  
150 Ft.-Lbs. Hub Torque  
Relieve valve Over Torque Protection  
1" Pivot Pins Hitch  
1 Remotes Required - Hydraulic  
Doesn't Require 12 Volt DC  
394 Lbs Unit Weight (Shipping)  
Replacement Teeth: H3000 high speed teeth  
12 Teeth

Adapter sold separately.  
Hoses & couplers included.



## S18

### Skidsteer Mount Specs:

25-80 Recommended HP  
Check GPM & PSI for Max. Carrier Size  
Check Stump Cutting Size Chart for Hydraulic GPM

### Excavator Mount Specs:

1.5-4 Ton Recommended Carrier Size  
Check Motor Options for Hydraulic GPM

Gerotor Motor  
24" Rotor Size  
Cutting Wheel Speed Depends on GPM  
No limit Cutting Height - Above Ground  
10" Cutting Depth - Below Ground  
5" Maximum Cutting Depth - Per Pass  
22" Maximum Horizontal Cut  
Self-feeding Swing Arc  
250 Ft.-Lbs. Hub Torque  
Relieve valve Over Torque Protection  
1" Pivot Pins Hitch  
1 Remotes Required - Hydraulic  
Doesn't Require 12 Volt DC  
642 Lbs Unit Weight (Shipping)  
Replacement Teeth: S1000\*  
34 Teeth

Adapter sold separately.  
Hoses included.  
Couplers NOT included for high flow.

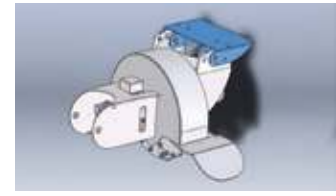

## EXCAVATOR ADAPTORS

Weld-on excavator adapter for S14 or S18.

### D002112

Unpainted & Not welded

### D001421

Painted & Welded

See the back of the catalog for our turn-key mounting options.



## SKIDSTEER ADAPTORS

D001126	S14 or S18 Mini Skid Steer Attachment	1" Pivot Pin	60 lbs
D001943	S14 or S18 Bob Cat Mini Skid Steer Attachment (35.5" wide)	1" Pivot Pin	60 lbs
D001127	S14 or S18 Universal Skid Steer Attachment	1" Pivot Pin	60 lbs
D003504	S14 or S18 ASV & Terex RC30 & PT30 Skid Steer Plate		



## STUMP CUTTING TIMES BASED ON 24" STUMP

MOTOR	CASE DRAIN	PSI	12 GPM	15 GPM	20 GPM	25 GPM	30 GPM	35 GPM	40 GPM	CC	MOTOR TYPE	RPM AT MAX GPM
S250 Motor Available for: S14	Not required	2,500	50 min	40 min	--	--	--	--	--	50	Roller Vane	910
		3,000	40 min	35 min	--	--	--	--	--			
S450 Motor Available for: S14, S18	Not required	2,500	60 min	40 min	35 min	--	--	--	--	125	Roller Vane	520
		3,000	50 min	30 Min	30 Min	--	--	--	--			
S550 Motor Available for: S18	Recommended	3,000	--	30 Min	25 Min	20 min	16 min	--	--	130	Roller Vane	700
		3,500	--	30 Min	25 Min	20 min	16 min	--	--			
S650 Motor Available for: S18	Recommended	3,000	--	--	40 min	25 min	15 min	12 min	10 min	245	Roller Vane	540
		3,500	--	--	40 min	25 min	15 min	12 min	10 min			

\*Motor will run at this PSI but excess pressure is dumping over relief.

# **STUMP GRINDERS**

---

## **ALTERNATIVE MODELS**

**FREE**  
6 Pack  
REPLACEMENT  
TEETH  
WITH PURCHASE  
SEE ONLINE FOR DETAILS



# ALTERNATIVE MODELS



**8 WEEKS  
SAVE \$8%**



## WB44 WALK BEHIND

- 13 HP-Honda GX390 389cc Motor
- 13" Cutting Wheel
- 2 Band V-Belt Drive
- Manual Walk Behind Wheel Drive
- Centrifugal Clutch
- 15" Tires
- 80" Length
- 29.75" Width
- 370 Lbs Unit Weight (Shipping)
- Replacement Teeth: H3000 high speed teeth
- 12 Teeth

## HGW30 SELF-PROPELLED

- 35 HP-Kohler 999cc Motor
- 19" Rotor Size
- Cutting Wheel Speed 1800 RPM
- 28" Height - Above Ground
- 12" Cutting Depth - Below Ground
- 3" Maximum Cutting Depth - Per Pass
- 46" Maximum Horizontal Cut
- 85° Swing Arc
- Relieve valve Over Torque Protection
- 3300 RPM input speed
- Manual Control
- 2-wheel Drive
- 105" Length
- 35" Width
- 1820 Lbs Unit Weight (Shipping)
- 2195 Lbs Unit Weight - with Optional Weight Kit (Shipping)
- Replacement Teeth: H3000 high speed teeth
- 16 Teeth

D003888 Weight kit (Priced Separately)

## HGS50F CHRISTMAS TREE STUMP GRINDER

- 20-42 GMP Motor
- 90 HP bevel gearbox
- 36 carbide tipped cutting teeth
- 6" wide rotor
- Nylon wrapping hoses for extra protection
- Heavy Duty frame
- Angled skidsteer plate for better visibility
- Powder coated finish and crated to ship
- Anti-slip safety pads on step
- Chain curtain to contain flying chip
- Replacement Teeth: S1000\*
- 28 teeth

# AVAILABLE OPTIONS

## TRACTOR MODEL EXTERNAL CONTROL

### PART# S1050

This optional control is mounted on an adjustable arm. The control is great for smaller tractors with limited HP for better cutting control and required for tractors with only one remote. Recommended for improved feathering control on smaller tractors.

Not available for 1P24



# SCREW SPLITTERS STUMP PLANERS



## PRODUCT FEATURES

- Heavy duty construction with a durable powder coat finish
- Easy to change bits from screw splitter to stump planer
- Hydraulically-driven planetary drive up to 11,000 ft./lbs. of torque
- No 12V electrical connection required
- Flange protects the main shaft seal to prevent damage from debris
- Hardened replaceable entry tip for extra-long life

Visit [baumalight.com](http://baumalight.com) for additional product information and product videos.

# SKIDSTEER MOUNT MODELS



## RSS380

Carrier weight for planer: 5000 lbs. (Max)  
Carrier weight for splitter: 7000 lbs. (Max)  
Recommended GPM: 20-40  
Max GPM: 45  
Recommended PSI: 2500-3000  
Max PSI: 3500  
2" Hex Planetary Drive  
Hoses Included\*



## RSS580

Carrier weight for planer: 6000 lbs. (Max)  
Carrier weight for splitter: 7000 lbs. (Max)  
Recommended GPM: 20-40  
Max GPM: 45  
Recommended PSI: 2500-3000  
Max PSI: 3500  
2" Hex Planetary Drive  
Hoses Included\*



## RSS780

Carrier weight for planer: 10,000 lbs. (Max)  
Carrier weight for splitter: 12,000 lbs. (Max)  
Recommended GPM: 20-55  
Max GPM: 65  
Recommended PSI: 2500-4500  
Max PSI: 5000  
8 Bolt Flange Planetary Drive  
Hoses Included\* (Case drain critical)

\*Hoses included on Skidsteer models, but no couplers.

# EXCAVATOR MOUNT MODELS

## RSX380

Bolt-on Adaptor  
Carrier weight:  
Planer: 5 Ton (Max)  
Splitter: 10 Ton (Max)  
Recommended GPM: 20-40  
Max GPM: 45  
Recommended PSI: 2500-3000  
Max PSI: 3500  
2" Hex Planetary Drive  
Hoses Not Included



## RSX580

Bolt-on Adaptor  
Carrier weight:  
Planer: 8 Ton (Max)  
Splitter: 10 Ton (Max)  
Recommended GPM: 20-40  
Max GPM: 45  
Recommended PSI: 2500-3000  
Max PSI: 3500  
2" Hex Planetary Drive  
Hoses Not Included



## RSX780

Bolt-on Adaptor  
Carrier weight:  
Planer: 18 Ton (Max)  
Splitter: 20 Ton (Max)  
Recommended GPM: 20-55  
Max GPM: 65  
Recommended PSI: 2500-4500  
Max PSI: 5000  
8 Bolt Flange Planetary Drive  
Hoses Not Included



# SCREW SPLITTER TOOLS



MODEL	DESCRIPTION
D002507	2" Hex 14x8 splitter cone assembly with replaceable tip
D003935	8-bolt flange mount 14x8 splitter cone assembly with replaceable tip
D002506	Splinter Tip - Hardened 4140 40/45RC for D002507 & D003935

# FLOW & PRESSURE SPECIFICATIONS

## RSS380, RSS580, RSX380, RSX580

GPM	2,000 PSI	2,500 PSI	3,000 PSI	3,500 PSI
20	45	2,294	43	2,870
24	54	2,289	51	2,879
28	63	2,281	61	2,870
32	72	2,243	70	2,841
40	90	2,167	87	2,769

■ RPM ■ Foot Pounds Torque Case Drain: Good to Have

## RSS780, RSX780

GPM	3,000 PSI	3,300 PSI	4,000 PSI
20	19	8,424	19
25	24.7	8,424	24.7
30	29.6	8,424	29.6
40	39	8,424	39
50	49	8,424	49
60	59	8,424	59
70	69	8,424	69

■ RPM ■ Foot Pounds Torque Case Drain: Crucial

# STUMP PLANER TOOLS



MODEL	DESCRIPTION
D002771	2" Hex 20" dia. 4-knife stump planer
D003381	8-bolt flange mount stump planer
D003508	Planer Spiral Tip - 4140 40/45RC for D002771 & D003381
D003930	Small blade assembly for D002771 Planer
D003434	Small Blade Assembly for D003381 Planer

# TREE SHEARS SKIDSTEER/EXCAVATOR





# SKIDSTEER TREE SHEARS



**ISR 90° ROTATE SERIES**

**ISH HORIZONTAL 500 SERIES**

**ISH HORIZONTAL 700 SERIES**

**Optional Hand-Held Control**

D005796 - Available hand-held wired control for skidsteer Tree Shears, connects to male AUX with a 16ft wire

## MODEL SPECIFICATIONS

MODEL	CARRIER	BLADE ANGLE	WEIGHT CLASS	LIMB SIZE	GRABBER	GPM
ISR512	Skidsteer	Rotating	5,000 - 8,000	12	No	15-60
ISH510G	Skidsteer	Horizontal	4,000 - 7,000	10	Yes	10-50
ISH512G	Skidsteer	Horizontal	5,000 - 8,000	12	Yes	15-60
ISH712G	Skidsteer	Horizontal	6,000 - 12,000	12	Yes	15-60

## TREE SIZE CUTTING PERFORMANCE

MODEL	WOOD TYPE	2000 PSI	2500 PSI	2800 PSI	3000 PSI	3400 PSI	4000 PSI
ISR512	Hardwood	N/A	5"	9"	10"	11"	12"
	Softwood	5"	9"	10"	11"	12"	12"
ISH510G	Hardwood	N/A	4"	7"	8"	9"	10"
	Softwood	4"	7"	8"	9"	10"	10"
ISH512G	Hardwood	N/A	5"	9"	10"	11"	12"
	Softwood	5"	9"	10"	11"	12"	12"
ISH712G	Hardwood	8"	10"	11"	12"	12"	12"
	Softwood	10"	11"	12"	12"	12"	12"



# TREE PULLERS

## SKIDSTEER



### PRODUCT FEATURES

- Cross over relief to protect over pressurizing
- Standard flat faced hydraulic couplers included
- Nylon wrapped hoses
- Spring mounted strain relief hose holder prevents pinching, but allows full forward curl
- Anti-slip safety step pads

Visit [baumalight.com](http://baumalight.com) for additional product information and product videos.



ISH3M MINI SKIDSTEER



ISH3P SKIDSTEER

### ISH TREE PULLER MODEL SPECIFICATIONS

MODEL	CARRIER	LIMB SIZE	CYLINDER SIZE	PIN DIAMETER	SHIPPING SIZE	SKIDSTEER SIZE RANGE
ISH3M	Mini Skidsteer	2"	2" Bore	1"	33" x 28" x 15"	1,500 - 4,000 lbs
ISH3P	Skidsteer	4"	3" Bore	1.5"	40" x 50" x 21"	4,000 - 8,000 lbs

# EXCAVATOR TREE SHEARS

**BAUMALIGHT**

**SLIPPER SHIPPING**  
CHECK LEAD TIMES ONLINE

SOLD BY  
EQUIPMENT DEALERS  
FOR LOCAL SUPPORT



**IXP 90° ROTATE 500 SERIES**



**IXV VERTICAL 500 SERIES**



**IXV VERTICAL 700 SERIES**

**Optional Hand-Held Control**

D005798 - Available hand-held wired control for excavator Tree Shears, connects to male AUX with no wire

## EXCAVATOR MODEL SPECIFICATIONS

MODEL	CARRIER	BLADE ANGLE	WEIGHT CLASS	LIMB SIZE	GRABBER	GPM
IXP508G	Excavator	Pivoting	3-10 ton	8	Yes	5-40
IXP510G	Excavator	Pivoting	5-15 ton	10	Yes	10-15
IXP512G	Excavator	Pivoting	8-20 ton	12	Yes	15-60
IXV508	Excavator	Vertical	3-10 ton	8	No	5-40
IXV512	Excavator	Vertical	8-20 ton	12	No	15-60
IXV715	Excavator	Vertical	15-26 ton	15	No	20-100

## TREE SIZE CUTTING PERFORMANCE

MODEL	WOOD TYPE	2000 PSI	2500 PSI	2800 PSI	3000 PSI	3400 PSI	4000 PSI
IXP508G	Hardwood	N/A	3"	5"	6"	7"	8"
	Softwood	3"	5"	6"	7"	8"	8"
IXP510G	Hardwood	N/A	4"	7"	8"	9"	10"
	Softwood	4"	7"	8"	9"	10"	10"
IXP512G	Hardwood	N/A	5"	9"	10"	11"	12"
	Softwood	5"	9"	10"	11"	12"	12"
IXV508	Hardwood	2"	5"	6"	7"	7"	7"
	Softwood	3"	6"	7"	8"	8"	8"
IXV512	Hardwood	4"	5"	9"	10"	11"	12"
	Softwood	5"	9"	10"	11"	12"	12"
IXV715	Hardwood	10"	11"	12"	13"	14"	15"
	Softwood	11"	12"	13"	14"	15"	15"



# TREE SAWS

---

## SKIDSTEER

**FREE**  
6 Pack **TEETH**  
REPLACEMENT  
WITH PURCHASE  
SEE ONLINE FOR DETAILS



### PRODUCT FEATURES

- 180 degree rotating cutting head (manual or actuator)
- Blade mounted on heavy duty bearing support
- Saw blade shield protects operator from debris
- Hoses are double shielded and then internally routed for protection
- Roll back mount angle for better flexibility
- Angled push bar with protective mesh
- Serrated steel front push bar plate
- Zinc plated greaseable pins to prevent corrosion

Visit [baumalight.com](http://baumalight.com) for additional product information and product videos.

# SKIDSTEER MOUNT MODELS



## DSM230

### 180° Manual Rotation

- Mini Skidsteer Connection
- Doesn't require 12 V Electric
- 6 to 20 gpm motor
- Hydraulic Hoses Included
- Hydraulic Couplers NOT Included
- 30" Blade Diameter (10" Max Cut)
- AR400 Steel Blade
- 3/4" Cut Thickness
- 12 Round Teeth with 3 Edges Per Tooth
- Replacement Teeth: H3000 High Speed

## DSM530

### 180° Manual Rotation

- Universal Skidsteer Connection
- Doesn't require 12 V Electric
- 10 to 40 gpm motor
- Hydraulic Hoses Included
- Hydraulic Couplers NOT Included
- 30" Blade Diameter (10" Max Cut)
- AR400 Steel Blade
- 3/4" Cut Thickness
- 12 Round Teeth with 3 Edges Per Tooth
- Replacement Teeth: H3000 High Speed

## DSA530

### 180° Actuator Rotation

- Universal Skidsteer Connection
- Helical Actuator
- 10 to 40 gpm motor
- Requires 1 Positive Pin AUX or 12 V Electric
- Hydraulic Hoses Included
- Hydraulic Couplers NOT Included
- 30" Blade Diameter (10" Max Cut)
- AR400 Steel Blade
- 3/4" Cut Thickness
- 12 round with 3 Edges Per Tooth
- Replacement Teeth: H3000 High Speed

### Optional Hand-Held Control

D005812 - Available hand-held wired control for skidsteer Tree Saws, connects to male AUX with a 16ft wire



# TREE SAWS

---

## EXCAVATOR

**FREE**  
6 Pack <sup>of REPLACEMENT</sup>  
TEETH  
WITH PURCHASE  
SEE ONLINE FOR DETAILS

### PRODUCT FEATURES

- 180 degree rotating cutting head - (DXM & DXA models only)
- Blade mounted on heavy duty bearing support
- Saw blade shield protects operator from debris
- Bolt-on excavator adapter mount
- Powder Coated
- Designed with maximum visibility for accurate cuts
- Fast lead time which is shown on our website
- Rotate teeth for double or triple life

Visit [baumalight.com](http://baumalight.com) for additional product information and product videos.

# EXCAVATOR MOUNT MODELS



## DXM530

### 180° Manual Rotation

Doesn't require 12 V Electric  
10 to 40 gpm motor  
Hydraulic Hoses NOT Included  
Hydraulic Couplers NOT Included  
30" Blade Diameter (10" Max Cut)  
AR400 Steel Blade - 3/4" Cut  
Thickness  
12 Round Teeth with 3 Edges  
Per Tooth  
Replacement Teeth:  
H3000 High Speed

### Optional Hand-Held Control

D005785 - Available hand-held wired control for excavator Tree Saws, connects to male AUX with no wire

## DXA530

### 180° Actuator Rotation

Helical Actuator  
10 to 40 gpm motor  
Requires 2 switchable positive  
pins for AUX control  
Hydraulic Hoses NOT Included  
Hydraulic Couplers NOT Included  
30" Blade Diameter (10" Max Cut)  
AR400 Steel Blade - 3/4" Cut  
Thickness  
12 Round Teeth with 3 Edges  
Per Tooth  
Replacement Teeth:  
H3000 High Speed

## DXH752

### Fixed Horizontal

Doesn't require 12 V Electric  
25 to 60 gpm motor  
Hydraulic Hoses NOT Included  
Hydraulic Couplers NOT Included  
52" Blade Diameter (20" Max Cut)  
1" Thick Steel Blade - 1-5/8" Cut  
Thickness  
17 Beaver Teeth with 4 Edges  
Per Tooth  
Replacement Teeth:  
B8000 Beaver Teeth

## DXD752

### 360° Slew Drive Rotation

Slew Drive  
25 to 60 gpm motor  
Requires 2 switchable positive  
pins for AUX control  
Hydraulic Hoses NOT Included  
Hydraulic Couplers NOT Included  
52" Blade Diameter (20" Max Cut)  
1" Thick Steel Blade - 1-5/8" Cut  
Thickness  
17 Beaver Teeth with 4 Edges  
Per Tooth  
Replacement Teeth:  
B8000 Beaver Teeth



**WELD-ON & TURN-KEY  
EXCAVATOR MOUNTING  
OPTIONS AVAILABLE!**

SEE BACK OF CATALOG FOR DETAILS.



# TREE SAWS

---

## TRACTOR

**FREE**  
6 Pack of REPLACEMENT  
TEETH  
WITH PURCHASE  
SEE ONLINE FOR DETAILS



### PRODUCT FEATURES

- Durable powder coated protective finish
- Handy pusher bar to guide falling trees
- Heavy duty gearbox delivers a smooth transfer of power
- A slip clutch protects the gearbox and drive system from over torquing
- Rotatable teeth with 3 edges
- Bolt-on blade direct to gearbox
- Designed to cut close to the ground
- Simple and rugged design

Visit [baumalight.com](http://baumalight.com) for additional product information and product videos.



# TRACTOR MOUNT MODELS



## DPH530

**50 Hp Maximum Engine**  
**40 Hp Maximum PTO**

- CAT 1 3-point hitch
- Quick Hitch Compatible: Yes
- Fixed Horizontal Blade
- 540 Drive Shaft
- Slip clutch Gearbox protection
- 30" Blade Diameter (9.5" Max Cut)
- AR400 Blade Material
- 3/4" Cut Thickness
- 15 Green Teeth with 3 Edges Per Tooth
- Replacement Teeth: H3000 High Speed

## DPH735

**85 Hp Maximum Engine**  
**75 Hp Maximum PTO**

- CAT 2 3-point hitch
- Quick Hitch Compatible: No
- Fixed Horizontal Blade
- 540 Drive Shaft
- Slip clutch Gearbox protection
- 35" Blade Diameter (12" Max Cut)
- Steel Blade Material
- 1-5/8" Cut Thickness
- 12 Beaver Teeth with 4 Edges Per Tooth
- Replacement Teeth: B8000 Beaver Teeth



# FELLER BUNCHERS

## SKIDSTEER / EXCAVATOR

**FREE**  
6 Pack of REPLACEMENT  
TEETH  
WITH PURCHASE  
SEE ONLINE FOR DETAILS



### PRODUCT FEATURES

- 52 inch cutting disc
- Cuts up to 20" trees
- 18 sharpenable teeth
- Powder coat finish
- Grabber arms secure trees and allow you to place where you want
- Double shielded hoses on skidsteer model
- Bunching arm to accumulate multiple small trees
- AUX plug in option

Visit [baumalight.com](http://baumalight.com) for additional product information and product videos.

# SKIDSTEER / EXCAVATOR MODELS



## SKIDSTEER MOUNTED MODEL

### FBS752

#### Skidsteer Mounted

#### Fixed Horizontal Blade

Universal Skidsteer Adaptor

25 to 60 gpm motor

4000 PSI

Requires 12 V Electric

Four 12V positive signals required

Wire Supplied to AUX on boom

Hoses Included. Couplers NOT Included

52" Diameter Blade

20" Max Cut

36" Throat Opening

Throat Opening at teeth: 36"

1" Steel Blade/ 1 5/8" Cut Thickness

2500 lbs

4 Edges Per Tooth

18 Teeth

B8000 Beaver Teeth

#### Optional Hand-Held Control

D004956 - If you don't have AUX, we have a wired hand-held control that connects to male AUX with a 16ft wire



## EXCAVATOR MOUNTED MODEL

### FBXD752

#### Excavator Mounted

#### 180° Rotation with Slew Drive

(Left - Flat - Right)

Bolt-on Adaptor

Helical Actuator

25 to 60 gpm motor

4000 PSI

Requires 12 V Electric

Six 12V switchable signals required

Wire & Plug NOT Supplied

Hoses & Couplers NOT Included

52" Diameter Blade

20" Max Cut

36" Throat Opening

1" Steel Blade

1 5/8" Cut Thickness

4 Edges Per Tooth

18 Teeth

B8000 Beaver Teeth



**WELD-ON & TURN-KEY  
EXCAVATOR MOUNTING  
OPTIONS AVAILABLE!**

SEE BACK OF CATALOG FOR DETAILS.



# ROTARY BRUSH CUTTERS

---

## TRACTOR

**FREE** REPLACEMENT BLADES WITH PURCHASE\*

\*Quality Parts and Service Dept.



### PRODUCT FEATURES

- Two cuts per pass for each blade
- PTO Shaft with Slip Disk Clutch for Gearbox protection
- Heavy duty chain curtain reduces discharge debris
- 1/4" deck thickness and powercoat finish
- Shield protects the output shaft from impact or contamination by debris
- Open front with push bar for extra control of felling trees

Visit [baumalight.com](http://baumalight.com) for additional product information and product videos.

# TRACTOR MOUNT MODELS



## CP560

- Open Front with Push Bar
- Chain Curtain Protection on Back
- 70" Path Width
- 60" Cutting Width
- Cuts as low as 2.5"
- 4 Blades
- 52 Slashes per Second
- CAT 2 3PH
- Quick Hitch Compatible: No
- 75 HP Engine Maximum
- 65 HP PTO Maximum
- 4000 lb. Minimum Carrier Weight
- 2-Disk Clutch System Protection
- 1/4" Steel Deck Structure
- 1600 lbs.

## CP572

- Open Front with Push Bar
- Chain Curtain Protection on Back
- 82" Path Width
- 72" Cutting Width
- Cuts as low as 2.5"
- 4 Blades
- 52 Slashes per Second
- CAT 2 3PH
- Quick Hitch Compatible: No
- 85 HP Engine Maximum
- 75 HP PTO Maximum
- 5000 lb. Minimum Carrier Weight
- 4-Disk Clutch System Protection
- 1/4" Steel Deck Structure
- 1900 lbs.

Full list of wear parts is available in the part breakdown section of the support page on [baumalight.com](http://baumalight.com).

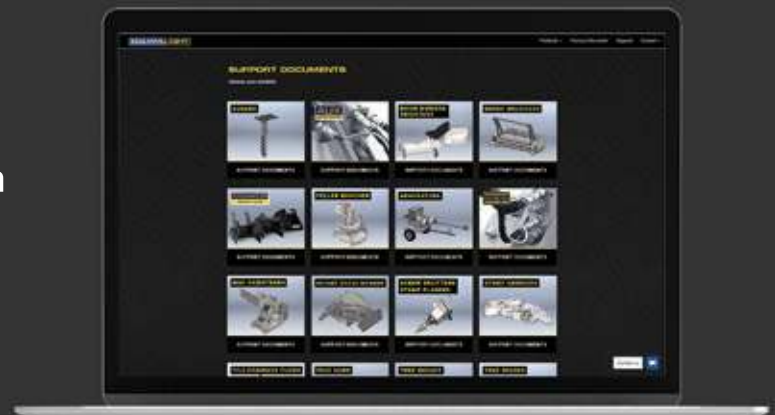

# ROTARY BRUSH CUTTERS

---

## SKIDSTEER

**FREE** REPLACEMENT  
BLADES WITH  
PURCHASE\*

Quality Parts and Service for Skid Steer



### PRODUCT FEATURES

- Two cuts per pass for each blade
- Gear box prevents cutting stress from being passed to the drive motor
- Hose armour prevents damage to hoses by falling brush or trees
- 4-way blade assembly provides up to 52 slashes per second (only applies to 500 Series)
- Shield protects the output shaft from impact or contamination by debris
- Open front with push bar for extra control of felling trees (only applies to 500 Series)

Visit [baumalight.com](http://baumalight.com) for additional product information and product videos.

# SKIDSTEER MOUNT MODELS



## CF360

Chain Curtain Protection on Front and Back  
70" Path Width  
60" Cutting Width  
Cuts as low as 2.5"  
2 Blades  
Universal Skid-Steer Plate Attachment  
Hoses & Couplers Included (M450 Motor)  
Hoses Included, Couplers NOT Included (M550 & M650 Motor)  
4000 lb. Minimum Carrier Weight  
Built In Hydraulic System Protection  
1/4" Steel Deck Structure  
1342 lbs.

**Motor Options:**

M450  
M550  
M650

## CF372

Chain Curtain Protection on Front and Back  
82" Path Width  
72" Cutting Width  
Cuts as low as 2.5"  
2 Blades  
Universal Skid-Steer Plate Attachment  
Hoses & Couplers Included (M450 Motor)  
Hoses Included, Couplers NOT Included (M550 & M650 Motor)  
4,500 lb. Minimum Carrier Weight  
Built In Hydraulic System Protection  
1/4" Steel Deck Structure  
1390 lbs.

**Motor Options:**

M450  
M550  
M650

## CF560

Open Front with Push Bar  
Chain Curtain Protection on Back  
70" Path Width  
60" Cutting Width  
Cuts as low as 2.5"  
4 Blades  
Universal Skid-Steer Plate Attachment  
Hoses & Couplers Included (M450 Motor)  
Hoses Included, Couplers NOT Included (M550 & M650 Motor)  
4500 lb. Minimum Carrier Weight  
Built In Hydraulic System Protection  
1/4" Steel Deck Structure  
1540 lbs.

**Motor Options:**

M450  
M550  
M650

## CF572

Open Front with Push Bar  
Chain Curtain Protection on Back  
82" Path Width  
72" Cutting Width  
Cuts as low as 2.5"  
4 Blades  
Universal Skid-Steer Plate Attachment  
Hoses & Couplers Included (M450 Motor)  
Hoses Included, Couplers NOT Included (M550 & M650 Motors)  
5000 lb. Minimum Carrier Weight  
Built In Hydraulic System Protection  
1/4" Steel Deck Structure  
1570 lbs.

**Motor Options:**

M450  
M550  
M650

## BRUSH CUTTING SIZE CHART (Brush Diameter in Inches)

MOTOR	MOTOR TYPE	PSI	CASE DRAIN	12 GPM	15 GPM	18 GPM	20 GPM	22 GPM	25 GPM	30 GPM	40 GPM
<b>Motor RPM</b>				<b>420</b>	<b>520</b>	<b>600</b>	<b>650</b>	<b>700</b>			
M450	Roller-Vane	2500 3000	Not Needed	0.75" 1"	1" 1.25"	1.25" 1.5"	1.5" 2"	2" 2.5"	Damage to motor will occur		
<b>Motor RPM</b>				<b>280</b>			<b>480</b>	<b>540</b>	<b>600</b>	<b>760</b>	
M550	Roller-Vane	2500 3000	Recommended	1" 1.25"	-- --	-- --	1.75" 2"	2" 2.25"	2.5" 2.75"	3" 3.25"	-- --
<b>Motor RPM</b>							<b>260</b>	<b>300</b>	<b>370</b>	<b>480</b>	<b>615</b>
M650	Roller-Vane	2500 3000	Recommended	-- --	-- --	-- --	1.75" 2"	2" 2.25"	2.5" 2.75"	2.75" 3"	3" 4"

Gearbox is a 1 to 1.46 increaser  
Triple diameter capacity for felling trees

# ROTARY BRUSH CUTTERS

---

## EXCAVATOR

**FREE** 16 1/4  
REPLACEMENT  
BLADES WITH  
PURCHASE\*  
Quality Parts Made in the USA



### PRODUCT FEATURES

- Two cuts per pass for each blade
- Bent axis piston motor
- Carburized alloy steel shafts, 2.95" diameter
- 3-way blade assembly provides 75-100 slashes per second
- Heavy duty top and bottom rotors secure the 3-way blade assembly
- Solid platform deck built with 1/4" AR400 steel(3/8" on CXC550)

Visit [baumalight.com](http://baumalight.com) for additional product information and product videos.



# EXCAVATOR MOUNT MODELS



## CXC530

40" Path Width  
30" Cutting Width  
Cuts as low as 2.5"  
3 Blades  
80 Slashes per Second  
Bolt-on Attachment  
2 Ton Min Carrier Weight (Max 10 Ton)  
Hydraulic Relief Valve System Protection  
1/4" AR400 Steel Deck  
Hoses & Couplers NOT Included  
550 lbs.

**Motor Options:**

HX508  
HX510  
HX530



## CXC542

50" Path Width  
42" Cutting Width  
Cuts as low as 2.5"  
3 Blades  
80 Slashes per Second  
Bolt-on Attachment  
3 Ton Min Carrier Weight (Max 15 Ton)  
Hydraulic Relief Valve System Protection  
1/4" AR400 Steel Deck  
Hoses & Couplers NOT Included  
640 lbs.

**Motor Options:**

HX530  
HX550  
HX570



## CXC550

67" Path Width  
50" Cutting Width  
Cuts as low as 2.5"  
3 Blades  
90 Slashes per Second  
Bolt-on Attachment  
8 Ton Min Carrier Weight (Max 20 Ton)  
Hydraulic Relief Valve System Protection  
3/8" AR400 Steel Deck  
Hoses & Couplers NOT Included  
1380 lbs.

**Motor Options:**

HX550  
HX570  
HX590

## BRUSH CUTTING SIZE CHART (Brush Diameter in Inches)

MOTOR	PSI	CASE DRAIN	6 GPM	12 GPM	15 GPM	20 GPM	25 GPM	30 GPM	35 GPM	40 GPM	45 GPM	50 GPM
<b>RPM</b>			<b>827</b>	<b>1637</b>	<b>2046</b>							
HX508	3000	Critical	0.5"	2"	2.25"	--	--	--	--	--	--	--
	3500		0.75"	2.5"	2.75"	--	--	--	--	--	--	--
	4000		1.25"	2.75"	3"	--	--	--	--	--	--	--
<b>RPM</b>				<b>1190</b>	<b>1492</b>	<b>1990</b>						
HX510	3000	Critical	--	2.25"	2.5"	2.75"	--	--	--	--	--	--
	3500		--	2.75"	3"	3.5"	--	--	--	--	--	--
	4000		--	3"	3.25"	3.75"	--	--	--	--	--	--
<b>RPM</b>					<b>1075</b>	<b>1450</b>	<b>1800</b>					
HX530	3000	Critical	--	--	2.75"	3"	3.5"	--	--	--	--	--
	3500		--	--	3.5"	3.75"	4"	--	--	--	--	--
	4000		--	--	3.75"	4"	4.25"	--	--	--	--	--
<b>RPM</b>						<b>1072</b>	<b>1340</b>	<b>1600</b>				
HX550	3000	Critical	--	--	--	3.5"	3.75"	4"	--	--	--	--
	3500		--	--	--	4"	4.25"	4.5"	--	--	--	--
	4000		--	--	--	4.25"	4.5"	4.75"	--	--	--	--
<b>RPM</b>							<b>1019</b>	<b>1223</b>	<b>1427</b>	<b>1631</b>		
HX570	3000	Critical	--	--	--	--	4"	4.5"	5"	5.5"	--	--
	3500		--	--	--	--	4.5"	5"	5.5"	6"	--	--
	4000		--	--	--	--	4.75"	5.5"	6"	7"	--	--
<b>RPM</b>								<b>946</b>	<b>1100</b>	<b>1260</b>	<b>1420</b>	<b>1580</b>
HX590	3000	Critical	--	--	--	--	--	5"	5.5"	6"	7"	8"
	3500		--	--	--	--	--	5.5"	6"	7"	8"	9"
	4000		--	--	--	--	--	6"	7"	8"	9"	10"

Triple diameter capacity for felling trees, a rotor speed of over 1,800 rpm is not recommended on 42" model or larger

# **BOOM MOWERS**

---

## **SKIDSTEER**



### **PRODUCT FEATURES**

- Curved boom for extra clearance
- Boom folds up for travel
- Pressure gauge to see your work load
- AR400 steel plate used on booms
- Available with AUX in-cab controls
- Armoured and sleeved hose protection
- Zinc plated greaseable pins
- Heavy duty cylinders
- Anti-slip mat for easy access to cab

Visit [baumalight.com](https://www.baumalight.com) for additional product information and product videos.

# SKIDSTEER MODELS



**SWA500 SERIES**



**SWF500 SERIES**



**SWA700 SERIES**

## SWA540

4,500 lbs. Minimum Carrier Weight  
6 ft. Reach (when flat)  
48" Head (38 flail clusters)  
Single Arm Boom  
F2000 Flail Teeth (F3000 Teeth Optional)  
1,775 lbs.

## SWA550

5,000 lbs. Minimum Carrier Weight  
7.5 ft Reach (when flat)  
60" Head (48 flail clusters)  
Single Arm Boom  
F2000 Flail Teeth (F3000 Teeth Optional)  
1,900 lbs.

## SWA560

5,500 lbs. Minimum Carrier Weight  
10 ft Reach (when flat)  
60" Head (48 flail clusters)  
Single Arm Boom  
F2000 Flail Teeth (F3000 Teeth Optional)  
1,750 lbs.

## SWF560

6,000 lbs. Minimum Carrier Weight  
10 ft Reach (when flat)  
48" Head (38 flail clusters)  
Boom & Stick  
F2000 Flail Teeth (F3000 Teeth Optional)  
1,650 lbs.

## SWF580

8,000 lbs. Minimum Carrier Weight  
14 ft Reach (when flat)  
48" Head (38 flail clusters)  
Boom & Stick  
F2000 Flail Teeth (F3000 Teeth Optional)  
1,750 lbs.

## SWA750

8,000 lbs. Minimum Carrier Weight  
7 ft Reach (when flat)  
42" Head (3 blades)  
Single Arm Boom  
Rotary Cutter Blades (CXC542)  
2,050 lbs.

See control options below.  
Hoses included, couplers not included.  
Custom configurations may be available upon request.

## MOTOR OPTIONS Running a skidsteer at half throttle is ideal.

MOTOR	MOTOR TYPE	CC	CASE DRAIN	IDEAL RPM	20 GPM	25 GPM	30 GPM	35 GPM	40 GPM
D510*	Piston	34	Critical	2200	1500 RPM	2000 RPM	2500 RPM	2900 RPM	3400 RPM
D530*	Piston	47	Critical	2100	1000 RPM	1500 RPM	1800 RPM	2100 RPM	2500 RPM
HX550**	Piston	64	Critical	1400	800 RPM	1100 RPM	1350 RPM	1600 RPM	1875 RPM
HX570**	Piston	84	Critical	1200	600 RPM	850 RPM	1000 RPM	1200 RPM	1450 RPM

\* 500 Series brush cutting size charts are available online at baumalight.com  
\*\* 700 Series brush cutting size charts are available in the Rotary Brush Mower section of this catalog

## CONTROLLER OPTIONS Must be priced separately.

SERIES	PART #	REQUIRED LIVE AUX PINS ON BOOM	CONTROLLER DESCRIPTION
SWA	D004904 **	4 live switchable	Best option - use buttons built right into joy sticks in skidsteer
	D004905 **	3 live switchable	Second Best option - use joystick buttons - required to hold two for some functions
	D004906	Plug into 12V in cab	Plug into D004904 and have a control box on your lap - D004904 also needed
	D004907 ~	Plug into 12V in cab	Plug into D004905 and have a control box on your lap - D004905 also needed
SWF	D004908 **	6 live switchable	Best option - use buttons built right into joy sticks in skidsteer
	D004909 **	4 live switchable	Second Best option - use joystick buttons - required to hold two for some functions
	D004910	Plug into 12V in cab	Plug into D004908 and have a control box on your lap - D004908 also needed
	D004911 ~	Plug into 12V in cab	Plug into D004909 and have a control box on your lap - D004909 also needed

\*\*Add \$500 if field installed  
~Operation for this option will be difficult

# BRUSH MULCHERS

---

## TRACTOR



### PRODUCT FEATURES

- Integrated push bar bends taller brush
- Spiral tooth pattern for smoother mulching
- Powder coated heavy duty frame
- Heavy duty gearbox for high performance
- Reinforced belt delivers force from the gear box to the rotor
- Hydraulic door opens and closes to control mulching action (500 and 700 Series)

Visit [baumalight.com](http://baumalight.com) for additional product information and product videos.

# TRACTOR MOUNT MODELS



## FMP260

- 72" Path Width
- 60" Rotor Width
- 25 HP Engine Minimum (30 HP Maximum)
- Level Cutting Depth
- 48 blade clusters
- 1.5" Rotor Shaft
- 19" Rotor Diameter (tool tips)
- 227 lb. Rotor (with tools)
- CAT 1 3PH
- Quick Hitch Compatible: Yes
- 540 RPM Drive Speed
- 1 3/8" Gearbox Spline Size
- 1 3/8" Tractor End Spline Size
- Slip Clutch Protection
- 900 lb.
- FMP260-F2000 Flail Teeth\* (Standard)
- FMP260-F3000 Flail Teeth\* (Optional)



## MP972

- 84" Path Width
  - 72" Rotor Width
  - 90 HP Engine Minimum (135 HP Maximum)
  - 125 HP PTO Maximum
  - Level to 2.5" Below Cutting Depth
  - Front and rear doors hydraulically controlled from the cab
  - 2" Rotor Shaft
  - 18.5" Rotor Diameter (tool tips)
  - 1,105 lb. Rotor (with tools)
  - CAT 2 or 3 3PH
  - Quick Hitch Compatible: No
  - 1000 RPM Drive Speed
  - 1 3/8" Gearbox Spline Size
  - 1 3/8" Tractor End Spline Size
  - Slip Clutch Protection
  - 3200 lb.
  - 43 Teeth
  - 2 hydraulic remotes required
  - R9000 Ripper Teeth\* (Standard)
  - T9000 Planer Teeth\* (Can be switched out by customer only)
- Max 110 Hp (1,000 RPM)      Optional 540 RPM
- Optional larger PTO shaft to increase HP
- Not to exceed 165 engine HP (1,000 RPM)
  - 1.75" Tractor End Spline (20-spline)

## BRUSH CUTTING SIZE CHART (Brush Diameter in Inches)

MODEL	TRACTOR SPEED	RPM	18 HP	25 HP	30 HP	35 HP	100 HP	125 HP	150 HP
FMP260-F2000	Low Gear		0.25"	0.375"	0.5"	0.75"	--	--	--
	Creeper	1800	0.375"	0.5"	0.75"	1"	--	--	--
	Hydrostatic		0.375"	0.5"	0.75"	1"	--	--	--
FMP260-F3000	Low Gear		0.5"	0.75"	1"	1.5"	--	--	--
	Creeper	1800	0.75"	1"	1.5"	2"	--	--	--
	Hydrostatic		0.75"	1"	1.5"	2"	--	--	--
MP972	Low Gear		--	--	--	--	7"	9"	10"
	Creeper	1800	--	--	--	--	9"	10"	12"
	Hydrostatic		--	--	--	--	13"	15"	17"

Double brush size for "stop and chew" cutting.

NOTICE: HP value must never be exceeded or slip clutch will burn, warranty is void

# TRACTOR MOUNT MODELS



## MP348

60" Path Width  
 48" Rotor Width  
 25 HP Engine Minimum (50 HP Maximum)  
 40 HP PTO Maximum  
 Level Cutting Depth  
 2" Rotor Shaft  
 15" Rotor Diameter (tool tips)  
 230 lb. Rotor (with tools)  
 CAT 1 3PH  
 Quick Hitch Compatible: No  
 540 RPM Drive Speed  
 1 3/8" Gearbox Spline Size  
 1 3/8" Tractor End Spline Size  
 Slip Clutch Protection  
 1050 lb.  
 H3000 Speed Teeth\*  
 60 Teeth

## MP360

72" Path Width  
 60" Rotor Width  
 30 HP Engine Minimum (55 HP Maximum)  
 45 HP PTO Maximum  
 Level Cutting Depth  
 2" Rotor Shaft  
 15" Rotor Diameter (tool tips)  
 315 lb. Rotor (with tools)  
 CAT 1 3PH  
 Quick Hitch Compatible: No  
 540 RPM Drive Speed  
 1 3/8" Gearbox Spline Size  
 1 3/8" Tractor End Spline Size  
 Slip Clutch Protection  
 1200 lb.  
 H3000 Speed Teeth\*  
 74 Teeth

## BRUSH CUTTING SIZE CHART (Brush Diameter in Inches)

MODEL	TRACTOR SPEED	RPM	25 HP	30 HP	40 HP	55 HP
300 Series	Low Gear Slow Reverse	1800	0.5"	1"	1.5"	2"
	Low Gear Stop & Chew		1"	1.5"	2"	2.5"
	Hydrostatic Slow Reverse		1.5"	2"	2.5"	3"
	Hydrostatic Stop & Chew		2"	3"	4"	5"

Double brush size for "stop and chew" cutting.

NOTICE: This value must never be exceeded or slip clutch will burn, warranty is void



**MP560**

- 75" Path Width
- 60" Rotor Width
- 45 HP Engine Minimum (75 HP Maximum)
- 65 HP PTO Maximum
- 1.5" Above to 1" Below Grade Cutting Depth
- Back door hydraulically controlled from the cab gives control of the mulching action
- 2" Rotor Shaft
- 15" Rotor Diameter (tool tips)
- 575 lb. Rotor (with tools)
- CAT 2 3PH
- Quick Hitch Compatible: No
- 540 RPM Drive Speed
- 1 3/8" Gearbox Spline Size
- 1 3/8" Tractor End Spline Size
- Slip Clutch Protection
- 2145 lb.
- 126 Teeth
- 1 hydraulic remote required
- P5000 Planer Teeth\* (Standard)
- R5000 Ripper Teeth\* (Can be switched out by customer only)

**MP572**

- 87" Path Width
- 72" Rotor Width
- 50 HP Engine Minimum (125 HP Maximum)
- 115 HP PTO Maximum
- 1.5" Above to 1" Below Grade Cutting Depth
- 2" Rotor Shaft
- 15" Rotor Diameter (tool tips)
- 700 lb. Rotor (with tools)
- CAT 2 3PH
- Quick Hitch Compatible: No
- 1000 RMP Drive Speed
- Optional 540 RPM Drive Speed (Max 110 HP)
- 1 3/8" Gearbox Spline Size
- 1 3/8" Tractor End Spline Size
- Slip Clutch Protection
- 2500 lb.
- 160 Teeth
- 2 hydraulic remotes required
- P5000 Planer Teeth\* (Standard)
- R5000 Ripper Teeth\* (Can be switched out by customer only)
- Optional 540 RPM Gearbox
- Not to exceed 110 Hp

**BRUSH CUTTING SIZE CHART (Brush Diameter in Inches)**

MODEL	TRACTOR SPEED	RPM	45 HP	50 HP	60 HP	65 HP	68 HP	75 HP	100 HP	125 HP
MP548/ MP560	Low Gear		1"	1.5"	2"	--	2.5"	--	--	--
	Creeper	1800	2"	2.5"	3"	--	4"	--	--	--
	Hydrostatic		3"	4"	5"	--	6"	--	--	--
MP572	Low Gear		--	--	--	2.5"	--	3"	3.5"	4"
	Creeper	1800	--	--	--	4"	--	5"	6"	7"
	Hydrostatic		--	--	--	6"	--	8"	10"	12"

Double brush size for "stop and chew" cutting.

NOTICE: HP value must never be exceeded or slip clutch will burn, warranty is void

# BRUSH MULCHERS

## SKIDSTEER



### PRODUCT FEATURES

- Integrated push bar bends taller brush
- Spiral tooth pattern for smoother mulching
- Powder coated heavy duty frame
- Armoured and sleeved hose protection
- V-Notch hardened tooth holders resist bending (500 Series)
- Over-torque protection relief valve protects motor
- Reinforced belt delivers force from the gearbox to rotor

Visit [baumalight.com](https://www.baumalight.com) for additional product information and product videos.



# SKIDSTEER MOUNT MODELS



## FMM148

- 61" Path Width
- 48" Rotor Width
- 4,000 lb min carrier weight
- Level Cutting Depth
- Swing Holder Style
- 19" Rotor Diameter (tool tips)
- 185 lb. Rotor (with tools)
- Built-In Relief System Protection
- Hydraulic Couplers Included
- 585 lb. Unit Shipping Weight
- 38 Teeth
- FMM148-F2000 Flail Teeth\* (Standard)
- FMM148-F3000 Flail Teeth\* (Optional)

See back of Brush Mulcher section for motor specific brush size charts.  
 \*See front of the catalog for teeth details

## MS348

- 60" Path Width
- 48" Rotor Width
- 3000lb min carrier weight
- Level Cutting Depth
- Fixed Holder Style
- 15" Rotor Diameter (tool tips)
- 230 lb. Rotor (with tools)
- Built-In Relief System Protection
- Hydraulic Couplers Included
- 950 lb. Unit Shipping Weight
- 60 Teeth
- H3000\* Speed Teeth



# SKIDSTEER MOUNT MODELS



## MS548

62" Path Width  
 48" Rotor Width  
 4000lb min carrier weight  
 1.5" Above to 1" Below Grade Cutting Depth  
 Fixed Holder Style  
 15" Rotor Diameter (tool tips)  
 480 lb Rotor (with tools)  
 Built-In Relief System Protection  
 Large PSI pressure gauge for maintaining optimal flow  
 Check with Dealer for Couplers  
 1491 lb.  
 104 Teeth  
 P5000 Planer Teeth\* (Standard)  
 R5000 Ripper Teeth\* (Can be switched out by customer only)



## MS560

75" Path Width  
 60" Rotor Width  
 5500lb min carrier weight  
 1.5" Above to 1" Below Grade Cutting Depth  
 Fixed Holder Style  
 15" Rotor Diameter (tool tips)  
 575 lb. Rotor (with tools)  
 Built-In Relief Protection  
 Large PSI pressure gauge for maintaining optimal flow  
 Check with Dealer for Couplers  
 2115 lb.  
 126 Teeth  
 P5000 Planer Teeth\* (Standard)  
 R5000 Ripper Teeth\* (Can be switched out by customer only)

See back of Brush Mulcher section for MOTOR OPTIONS - BRUSH SIZE CHART  
 \*See front of the catalog for teeth details

## MS572

87" Path Width  
 72" Rotor Width  
 6000lb min carrier weight  
 1.5" Above to 1" Below Grade Cutting Depth  
 Fixed Holder Style  
 15" Rotor Diameter (tool tips)  
 700 lb. Rotor (with tools)  
 Built-In Relief Protection  
 Large PSI pressure gauge for maintaining optimal flow  
 Check with Dealer for Couplers  
 2266 lb.  
 160 Teeth  
 P5000 Planer Teeth (Standard)  
 R5000 Ripper Teeth (Can be switched out by customer only)





**MS960**

75" Path Width  
60" Rotor Width  
7,000lb min carrier weight  
2.25" above grade to 2.5" below grade  
Fixed Holder Style  
18.5" Rotor Diameter (tool tips)  
860 lb. Rotor (with tools)  
Built-In Relief Protection  
Large PSI pressure gauge for maintaining optimal flow  
Couplers NOT Included  
2,724 lb.  
38 Teeth  
R9000 Ripper Teeth (Standard)  
P9000 Planer Teeth (Can be switched out by customer only)

**MS972**

84" Path Width  
72" Rotor Width  
7,500lb min carrier weight  
2.25" above grade to 2.5" below grade  
Fixed Holder Style  
18.5" Rotor Diameter (tool tips)  
1,105 lb. Rotor (with tools)  
Built-In Relief Protection  
Large PSI pressure gauge for maintaining optimal flow  
Couplers NOT Included  
3115 lb.  
43 Teeth  
R9000 Ripper Teeth (Standard)  
P9000 Planer Teeth (Can be switched out by customer only)

See back of Brush Mulcher section for MOTOR OPTIONS - BRUSH SIZE CHART



**MS1160**

75" Path Width  
60" Rotor Width  
7,000lb min carrier weight  
1" above grade to 3" below grade  
Fixed Holder Style  
19.3" Rotor Diameter (tool tips)  
860 lb. Rotor (with tools)  
Built-In Relief Protection  
Large PSI pressure gauge for maintaining optimal flow  
Couplers NOT Included  
2,800 lb.  
31 Teeth  
R11000 Sharpenable Planer Teeth

# BRUSH MULCHERS

---

## EXCAVATOR



### PRODUCT FEATURES

- Spiral tooth pattern for smoother mulching
- Powder coated heavy duty frame
- V-North hardened tooth holders resist bending
- Over-torque protection relief valve protects motor
- Reinforced belt delivers force from the gearbox to rotor
- Overhung load adapter with tapered roller bearings
- Wire fencing protection kit
- Integrated skid shoes to float along ground

Visit [baumalight.com](http://baumalight.com) for additional product information and product videos.

# EXCAVATOR MOUNT MODELS



## MX230

38" Path Width  
 30" Rotor Width  
 6 Ton Maximum Carrier Weight  
 2 Ton Minimum Carrier Weight  
 Level Cutting Depth  
 Swing Holder Style  
 1.5" Rotor Shaft  
 17.25" Rotor Diameter (tool tips)  
 125 lb. Rotor (with tools)  
 Built-In Relief System Protection  
 500 lb.  
 22 Teeth  
 F2000 Flail Teeth\* (Standard)  
 F3000 Flail Teeth\* (Optional)



## MX330

38" Path Width  
 30" Rotor Width  
 8 Ton Maximum Carrier Weight  
 3 Ton Minimum Carrier Weight  
 Level Cutting Depth  
 Fixed Holder Style  
 2" Rotor Shaft  
 15" Rotor Diameter (tool tips)  
 175 lb. Rotor (with tools)  
 Built-In Relief System Protection  
 750 lb.  
 36 Teeth  
 H3000\* Speed Teeth

See back of Brush Mulcher section for MOTOR OPTIONS - BRUSH SIZE CHART



## MX530

40" Path Width  
 30" Rotor Width  
 12 Ton Maximum Carrier Weight  
 4 Ton Minimum Carrier Weight  
 Level Cutting Depth  
 Fixed Holder Style  
 2" Rotor Shaft  
 15" Rotor Diameter (tool tips)  
 300 lb. Rotor (with tools)  
 Built-In Relief System Protection  
 1036 lb.  
 64 Teeth  
 P5000 Planer Teeth\* (Standard)  
 R5000 Ripper Teeth\* (Can be switched out by customer only)

# EXCAVATOR MOUNT MODELS



## MX548

62" Path Width  
48" Rotor Width  
20 Ton Maximum Carrier Weight  
8 Ton Minimum Carrier Weight  
Level Cutting Depth  
Fixed Holder Style  
2" Rotor Shaft  
15" Rotor Diameter (tool tips)  
408 lb. Rotor (with tools)  
Built-In Relief System Protection  
Hoses & Couplers NOT Included  
2167 lb.  
104 Teeth  
P5000 Planer Teeth\* (Standard)  
R5000 Ripper Teeth\* (Can be switched out by customer only)



## MX548R with Root Rake

62" Path Width  
48" Rotor Width  
20 Ton Maximum Carrier Weight  
8 Ton Minimum Carrier Weight  
Level Cutting Depth  
Fixed Holder Style  
2" Rotor Shaft  
15" Rotor Diameter (tool tips)  
408 lb. Rotor (with tools)  
Built-In Relief System Protection  
Hoses & Couplers NOT Included  
2167 lb.  
104 Teeth  
P5000 Planer Teeth\* (Standard)  
R5000 Ripper Teeth\* (Can be switched out by customer only)

See back of Brush Mulcher section for MOTOR OPTIONS - BRUSH SIZE CHART



## MX948R

70" Path Width  
48" Rotor Width  
30 Ton Maximum Carrier Weight  
12 Ton Minimum Carrier Weight  
Level Cutting Depth  
Fixed Holder Style  
2" Rotor Shaft  
18.5" Rotor Diameter (tool tips)  
617 lb. Rotor (with tools)  
Built-In Relief System Protection  
Hoses & Couplers NOT Included  
2838 lb.  
27 Teeth  
R9000 Ripper Teeth\* (Standard)  
T9000 Planer Teeth\* (Can be switched out by customer only)

**MX960R**

90" Path Width  
 60" Rotor Width  
 33 Ton Maximum Carrier Weight  
 18 Ton Minimum Carrier Weight  
 Level Cutting Depth  
 Fixed Holder Style  
 2" Rotor Shaft  
 18.5" Rotor Diameter (tool tips)  
 860 lb. Rotor (with tools)  
 Built-In Relief System Protection  
 Hoses & Couplers NOT Included  
 2910 lb.  
 38 Teeth  
 R9000 Ripper Teeth\* (Standard)  
 T9000 Planer Teeth\* (Can be switched out by customer only)

**MX1148R**

70" Path Width  
 48" Rotor Width  
 30 Ton Minimum Carrier Weight  
 Level Cutting Depth  
 Fixed Holder Style  
 2" Rotor Shaft  
 18.5" Rotor Diameter (tool tips)  
 738 lb. Rotor (with tools)  
 Built-In Relief System Protection  
 Hoses & Couplers NOT Included  
 2959 lb.  
 25 Teeth  
 Sharpenable Planer

See back of Brush Mulcher section for MOTOR OPTIONS - BRUSH SIZE CHART

**MX1160R**

90" Path Width  
 60" Rotor Width  
 33 Ton Maximum Carrier Weight  
 18 Ton Minimum Carrier Weight  
 Level Cutting Depth  
 Fixed Holder Style  
 2" Rotor Shaft  
 18.5" Rotor Diameter (tool tips)  
 870 lb. Rotor (with tools)  
 Built-In Relief System Protection  
 Hoses & Couplers NOT Included  
 2925 lb.  
 31 Teeth  
 P11000 Ripper Teeth\* (Standard)  
 T9000 Planer Teeth\* (Can be switched out by customer only)

# SKIDSTEER & EXCAVATOR BRUSH CUTTING SIZE CHARTS

(Brush Diameter in Inches)

MOTOR	PSI	CASE DRAIN	12 GPM	15 GPM	18 GPM	20 GPM
<b>RPM</b>			<b>832</b>	<b>1060</b>	<b>1250</b>	<b>1390</b>
200 Series Motor F2000 Standard Cup Teeth	2500	Not	0.25"	0.375"	0.5"	0.75"
	3000	Important for Roller-Vane motors	0.375"	0.5"	0.75"	1"
	3500		0.375"	0.5"	0.75"	1"
<b>RPM</b>			<b>832</b>	<b>1060</b>	<b>1250</b>	<b>1390</b>
200 Series Motor F3000 Heavy Blade Teeth	2500	Not	0.5"	0.75"	1"	1.5"
	3000	Important for Roller-Vane motors	0.75"	1"	1.5"	2"
	3500		0.75"	1"	1.5"	2"
<b>RPM</b>			<b>832</b>	<b>1060</b>	<b>1250</b>	<b>1390</b>
300 Series Motor	2500	Not	0.75"	1"	1.25"	2"
	3000	Important for Roller-Vane motors	1"	1.25"	1.5"	2.5"
	3500		1"	1.25"	1.5"	2.5"

(Brush Diameter in Inches)

MOTOR	PSI	CASE DRAIN	8 GPM	12 GPM	15 GPM	20 GPM	25 GPM	30 GPM	35 GPM	40 GPM	45 GPM
<b>RPM</b>			<b>555</b>	<b>832</b>	<b>1060</b>	<b>1390</b>					
A450 Roller-Vane	2500	Not Needed	0.25"	0.75"	1"	1.5"	--	--	--	--	--
	3000	Not Needed	0.5"	1"	1.25"	2"	--	--	--	--	--
	3500	Recommended	0.5"	1"	1.25"	2"	--	--	--	--	--
<b>RPM</b>				<b>640</b>	<b>846</b>	<b>1100</b>	<b>1370</b>	<b>1600</b>			
B550 Roller-Vane	2500	Not Needed	--	0.25"	0.75"	1.25"	2.5"	3"	--	--	--
	3000	Recommended	--	0.5"	1"	1.75"	3"	3.5"	--	--	--
	3500	Needed	--	0.5"	1"	1.75"	3"	3.5"	--	--	--
<b>RPM</b>			<b>1090</b>	<b>1640</b>	<b>2050</b>						
C508 Bent Axis Piston	3000		1.5"	2.25"	2.75"	--	--	--	--	--	--
	3500	Critical	2"	2.75"	3.25"	--	--	--	--	--	--
	4000		2.5"	3.25"	4"	--	--	--	--	--	--
<b>RPM</b>				<b>1190</b>	<b>1490</b>	<b>2000</b>	<b>2490</b>				
C510 Bent Axis Piston	3000		--	2"	2.5"	3"	3.5"	--	--	--	--
	3500	Critical	--	2.5"	3"	3.5"	4.5"	--	--	--	--
	4000		--	3"	3.5"	4.5"	5"	--	--	--	--
<b>RPM</b>						<b>1450</b>	<b>1800</b>	<b>2100</b>			
C530 Bent Axis Piston	3000		--	--	--	3"	4"	5"	--	--	--
	3500	Critical	--	--	--	3.5"	4.5"	5.5"	--	--	--
	4000		--	--	--	4.5"	5"	5.75"	--	--	--
<b>RPM</b>							<b>1500</b>	<b>1800</b>	<b>2100</b>		
C540 Bent Axis Piston	3000		--	--	--	--	3.75"	5.5"	6"	--	--
	3500	Critical	--	--	--	--	4.25"	5.75"	6.5"	--	--
	4000		--	--	--	--	4.75"	6"	7"	--	--
<b>RPM</b>								<b>1600</b>	<b>1875</b>	<b>2140</b>	
C550 Bent Axis Piston	3000		--	--	--	--	--	5"	6.5"	7"	--
	3500	Critical	--	--	--	--	--	5.5"	7"	7.5"	--
	4000		--	--	--	--	--	5.75"	7.5"	8"	--

Double brush size for "stop and chew" cutting for skidsteer models ONLY

NOTICE: Max GPM value must NEVER be exceeded on roller-vane motors or failure will occur, Piston motors run much faster before failure will occur

NOTICE: Above GPM values are under load flow estimates





# NEW! Online Motor Option Calculator

Online tool to easily find the right Baumalight product and motor option for your carrier.  
[baumalight.com/motor-option-calculator](http://baumalight.com/motor-option-calculator)



(Brush Diameter in Inches)

MOTOR	PSI	CASE DRAIN	20 GPM	25 GPM	30 GPM	35 GPM	40 GPM	45 GPM	50 GPM	55 GPM	60 GPM
<b>RPM</b>						<b>1400</b>	<b>1630</b>	<b>1830</b>	<b>2030</b>		
C570 Bent Axis Piston	3000		--	--	--	6"	5.5"	7"	7.5"	--	--
	3500	Critical	--	--	--	6.5"	6"	7.5"	8"	--	--
	4000		--	--	--	7"	6.5"	8"	8.5"	--	--
<b>RPM</b>			<b>1450</b>	<b>1800</b>	<b>2100</b>						
C930 Bent Axis Piston	3000		4"	5"	6"	--	--	--	--	--	--
	3500	Critical	4.5"	5.5"	6.5"	--	--	--	--	--	--
	4000		5.5"	6"	7"	--	--	--	--	--	--
<b>RPM</b>				<b>1500</b>	<b>1800</b>	<b>2100</b>					
C940 Bent Axis Piston	3000		--	4.75"	6.5"	7"	--	--	--	--	--
	3500	Critical	--	5.25	6.75"	7.5"	--	--	--	--	--
	4000		--	5.75"	7"	8"	--	--	--	--	--
<b>RPM</b>					<b>1600</b>	<b>1875</b>	<b>2140</b>				
C950 Bent Axis Piston	3000		--	--	6"	7.5"	8"	--	--	--	--
	3500	Critical	--	--	6.5"	8"	8.5"	--	--	--	--
	4000		--	--	6.75	8.5"	9"	--	--	--	--
<b>RPM</b>						<b>1400</b>	<b>1630</b>	<b>1830</b>	<b>2030</b>		
C970 Bent Axis Piston	3000		--	--	--	6"	6.5"	8"	8.5"	--	--
	3500	Critical	--	--	--	7.5"	7"	8.5"	9"	--	--
	4000		--	--	--	8"	7.5"	9"	9.5"	--	--
<b>RPM</b>								<b>1400</b>	<b>1570</b>	<b>1750</b>	<b>1900</b>
C990 Bent Axis Piston	3000		--	--	--	--	--	6"	8.5"	10"	10.5"
	3500	Critical	--	--	--	--	--	6.5"	9"	10.5"	11"
	4000		--	--	--	--	--	7"	10"	11"	12"
<b>RPM</b>			<b>1450</b>	<b>1800</b>	<b>2100</b>						
C1130 Bent Axis Piston	3000		5"	6"	7"	--	--	--	--	--	--
	3500	Critical	5.5"	6.5"	7.5"	--	--	--	--	--	--
	4000		6.5"	7"	8"	--	--	--	--	--	--
<b>RPM</b>				<b>1500</b>	<b>1800</b>	<b>2100</b>					
C1140 Bent Axis Piston	3000		--	6.75"	8.5"	9"	--	--	--	--	--
	3500	Critical	--	7.25"	8.75"	9.5"	--	--	--	--	--
	4000		--	7.75"	9"	10"	--	--	--	--	--
<b>RPM</b>					<b>1600</b>	<b>1875</b>	<b>2140</b>				
C1150 Bent Axis Piston	3000		--	--	9"	10.5"	11"	--	--	--	--
	3500	Critical	--	--	9.5"	11"	11.5"	--	--	--	--
	4000		--	--	9.75"	11.5"	12"	--	--	--	--
<b>RPM</b>						<b>1400</b>	<b>1630</b>	<b>1830</b>	<b>2030</b>		
C1170 Bent Axis Piston	3000		--	--	--	10"	10.5"	12"	12.5"	--	--
	3500	Critical	--	--	--	11.5"	11"	12.5"	13"	--	--
	4000		--	--	--	12"	11.5"	13"	13.5"	--	--
<b>RPM</b>								<b>1400</b>	<b>1570</b>	<b>1750</b>	<b>1900</b>
C1190 Bent Axis Piston	3000		--	--	--	--	--	10.5"	13"	14.5"	15"
	3500	Critical	--	--	--	--	--	11"	13.5"	15"	15.5"
	4000		--	--	--	--	--	11.5"	14.5"	15.5"	16.5"

Double brush size for "stop and chew" cutting for skidsteer models ONLY

NOTICE: Same motor is used for 500, 700, 900 & 1100 series mulchers, the larger rotors in the bigger series can mulch more with the same motor

NOTICE: Above GPM values are under load flow estimates

# TILE DRAINAGE PLOW

## TRACTOR



### PRODUCT FEATURES

- Strong wear resistant AR400 shank
- Adjustable mast
- Durable powder coat finish
- Up to 5' trenching depth
- Hardened steel bushings
- Danfoss valve

Visit [baumalight.com](http://baumalight.com) for additional product information and product videos.

# TRACTOR MODELS



## UPP748

### 48" Max Depth

4" tile size  
15,000-25,000 lbs. recommended tractor weight  
(30,000 lbs. Max)  
Minimum tractor weight depends on soil  
CAT 3 Hitch size  
Quick Hitch Compatible: No  
\*2 remotes required  
Shank made with AR400 steel  
2,350 lbs. weight  
3,000 lbs. shipping weight

\*Add 1 extra remote for power tile feeder

## UPP760

### 60" Max Depth

4" & 6" tile size  
20,000-40,000 lbs. recommended tractor weight  
(45,000 lbs. Max)  
Minimum tractor weight depends on soil  
CAT 4 Hitch size  
Quick Hitch Compatible: No  
\*2 remotes required  
Shank made with 2" AR400 solid steel  
4,650 lbs. weight  
5,600 lbs. shipping weight



Optional Tile Feeder

As of January 1, 2021, trailers, plows and accessories are no longer offered with free freight.

## Available promotions

**8 WEEKS 8% SAVES \$8**

### Plan ahead and save

To reward and encourage you to plan ahead Baumalight is offering an 8% discount on pre-ordered drainage plows. This program allows you to order a plow at an 8% discount for delivery in 8 weeks. This program allows us to reward the prepared and also keep stock for the times when customers have immediate needs.

**FREE IN-FIELD TRAINING OR \$1000 CREDIT**

When you order a Baumalight drainage plow, receive an in-field training session or a \$1000 list price purchase credit. Training session to be provided by dealer or territory manager.

# TILE DRAINAGE PLOW TRAILER



## PRODUCT FEATURES

- Strong 2" AR400 shank
- Adjustable mast
- Durable powder coat finish
- 5' trenching depth
- Hardened steel bushings
- Danfoss valve

Visit [baumalight.com](http://baumalight.com) for additional product information and product videos.

**8 WEEKS  
SAVES 8%**

**FREE IN-FIELD  
TRAINING  
OR \$1000 CREDIT**



## TRAILER MODELS

### UPT760

#### 60" Max Depth

4" & 6" tile size

25,000-45,000 lbs. recommended tractor weight  
(50,000 lbs. Max)

Minimum tractor weight depends on soil

Draw bar hitch size

\*2 remotes required

Shank made with AR400 steel

\*Add 1 extra remote for power tile feeder

\*Must be loaded on a low deck truck or towed

As of January 1, 2021, trailers, plows and accessories are no longer offered with free freight.

## PRODUCT FEATURES

- Hydraulic hoist
- Fold in wing to load
- Hardened steel bushings

Visit **baumalight.com** for additional product information and product videos.



## TILE CART



### UST510

- Single axle
- Tractor draw bar hitch
- One remote required
- Two remotes if ordered with power table turner

As of January 1, 2021, trailers, plows and accessories are no longer offered with free freight.

## ACCESSORIES



### Laser Guidance System

Controlling bought from Latec  
Rugged, reliable and accurate, the Latec LT-180 is an affordable, automatic true self-leveling single slope laser. Ideal for drainage work, the Latec LT-180 is the perfect partner for your Undertow to ensure exceptional leveling when plowing.



### Heavy Duty Tripod

The Undertow's heavy duty tripod features fiberglass construction with extendable legs and an adjustment range of 3' 8" to 6'.



### Tile Feeder

The optional tile feeder is designed to assist tile movement while limiting stretch in the tile, thereby improving overall drainage performance.

Reccomended for use on all models

# EXCAVATOR

## MOUNTING



### OPTION 1: BLANK WELD ON PLATE

This blank plate is designed ready for you to weld on ear lugs for your specific Excavator application then bolted on to the attachment.

PART #	DESCRIPTION	WEIGHT (Lbs.)
D001161	Blank Weld-on Plate - Excavator up to 10 Ton	48
D004951	Set of 10 5/8" x 2" G5 bolts w/ lock nuts - Free if mount ordered w/ whole good	
D001419	Blank Weld-on Plate - Excavator over 8 Ton	90
D004952	Set of 26 5/8" x 2" G5 bolts w/ lock nuts - Free if mount ordered w/ whole good	



D001161



D001419

### OPTION 2: SEE LEADTIME ONLINE! TURN-KEY MOUNTING. PIN ON OR QUICK COUPLER

We also have turn-key options available for both pin on and quick attach mounting. With these options your attachment arrives ready to go to work. For Pin on mounting use the worksheet to get the correct measurements so we can design and build it.

CARRIER	WEIGHT (approx.)	CLASS	TON
Excavator	80 lbs	3	1.5 to 3
Excavator	100 lbs	5	3 to 6
Excavator	200 lbs	8	7 to 9
Excavator	225 lbs	10	10 to 11
Excavator	250 lbs	13	12 to 15
Excavator	275 lbs	15	16 to 19
Excavator	300 lbs	20	20 to 22
Excavator	325 lbs	25	23 to 29
Excavator	400 lbs	30	Over 30



Wedge

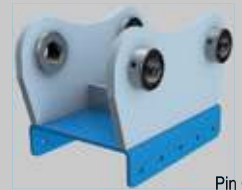

Pin On Grabber

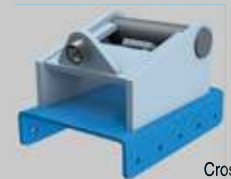

Cross Pin

### EXCAVATOR ADAPTOR PIN SIZES

PART NUMBER	CLASS	DIAMETER (mm)	TON
D003569	3	35-40	1.5 to 3
D003569	5	45-50	3 to 6
D003569	6	45-50	7 to 9
D003569	8	45-55	10 to 11
D003569	13	60-65	12 to 15
D003569	15	65-80	16 to 19
D003569	20	80	20 to 22
D003569	25	80-90	23 to 29
D003569	30	90-100	Over 30

### EXCAVATOR TO SKIDSTEER QUICK ATTACH



XQS10



XQS20

New shipping policy, please see last page

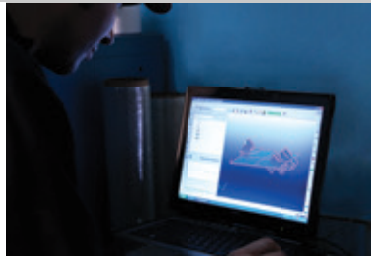

**VISIT US ONLINE**

**LEARN MORE**  
baumalight.com

**PIN-ON/PIN GRABBER COUPLER FORM**

Pin On or Pin Grabber (Circle one)

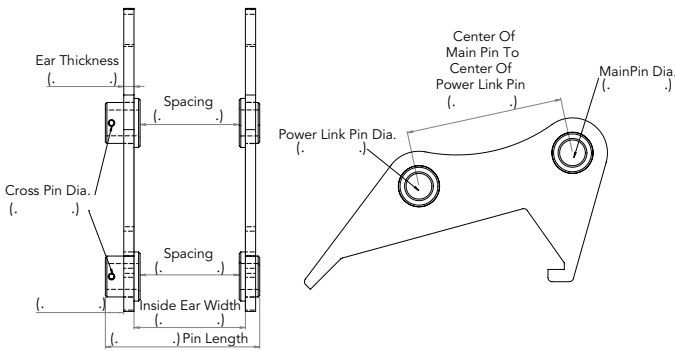

Please fill in all measurements

Check box If pins are required

**WEDGE COUPLER AND CROSS PIN FORM**

Please fill in all spaces below

Excavator Brand \_\_\_\_\_

Excavator Model \_\_\_\_\_

Coupler Brand \_\_\_\_\_

Coupler Model \_\_\_\_\_

Wedge Coupler, Cross Pin or Pin Grabber? \_\_\_\_\_

**COLOR OPTIONS**

Pricing is online at [www.baumalight.com](http://www.baumalight.com)

PART #	COLOR OPTIONS	AVAILABLE FOR ANY BAUMALIGHT PRODUCTS*
D001582	Green	Will increase lead-time Take Number of Business Days to build next order on <a href="http://www.suddenshipping.com">www.suddenshipping.com</a>
D001583	Orange	
D001584	Blue	
D001585	Red	

\*up to 8 weeks extended lead time on some products

CHOOSE YOUR CUSTOM  
**COLOR**

Match the color of your favorite tractor company for the factory look!  
Additional cost and delivery lead time applicable  
**CONTACT YOUR DEALER TODAY!**



**SHIPPING POLICY**

**WHOLE GOODS FREIGHT**

Baumalight whole good products include free freight to any non-remote Baumalight dealer in North America if no special arrangements are required for unloading. As of Jan 1 2021 Trailer plows and accessories no longer offered with free freight



**PARTS SHIPPING**

Parts orders over \$100 include free standard shipping to any non-remote location in North America if shipped standard. All orders under \$100 are subject to a \$20 flat rate shipping charge if shipped standard. Next Day Air or Express Courier rates are available at an additional cost for any value orders.

**SOLD BY**  
**EQUIPMENT DEALERS**  
**FOR LOCAL SUPPORT**

Most Tractor, Skidsteer or Excavator dealerships have access to the full line of Baumalight attachments.

Buy local through your Trusted Dealer for after-sales service, maintenance and product warranty.



**THREE WAYS TO SAVE!**

**VISIT OUR WEBSITE FOR CURRENT FACTORY DISCOUNT OFFERS**



**PRE-PRODUCTION TESTING**



**VIDEO/PHOTO SHOOTS**



**FLOOR AND DEMO MODELS**



**Manufactured by: MTB MFG. INC.**  
 4575 Powell Rd. Wallenstein, ON. Canada, N0B 2S0

sales@baumalight.com 866.820.7603

**baumalight.com**